



BN Products-USA, LLC

3450 Sabin Brown Road • Wickenburg, Arizona 85390

(800) 992-3833 • (928) 684-2813 • www.bnproducts.com

HB-16W Power Rebar Bender

Handling Instructions

Prior to use, please read these instructions carefully.



Important: To reduce rebar breakage, bend the rebar in increments by throttling the on/off trigger switch. Bending rebar in smaller stages allows for stress relief in the metal, reducing breakage.



BN Products-USA, LLC

3450 Sabin Brown Road • Wickenburg, Arizona 85390

(800) 992-3833 • (928) 684-2813 • www.bnproducts.com

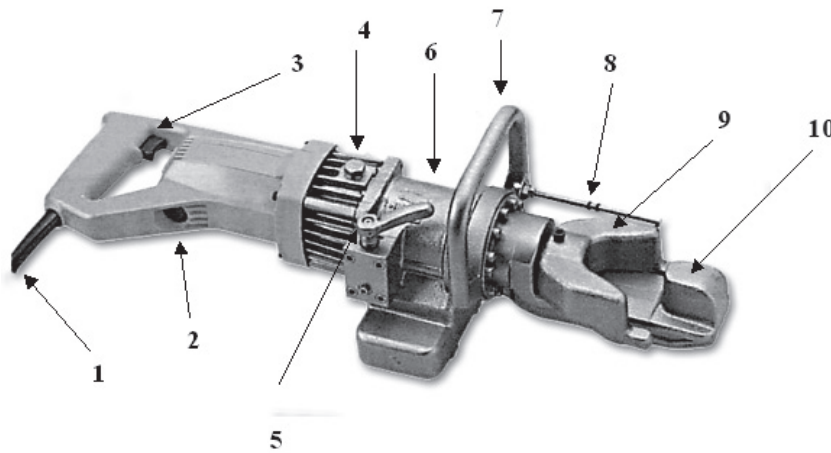

1. Electric cord
2. Electrical brush
3. On/Off switch
4. Oil plug
5. Valve lever
6. Hydraulic cylinder
7. Carrying handle
8. Bending angle marker
9. Pivot shoe
10. Housing

IMPORTANT SAFETY PRECAUTIONS

- Keep hands away from pivot shoe while operating.
- Disconnect tool from socket when not in use and before servicing.
- Maximum number of bar that can be bent at one time: Grade 60 or equivalent.

IMPORTANT -- Do not exceed the maximum number of bars that can be bent at one time.

Diameter of bar	3/8" (10mm)	1/2" (13mm)	5/8" (16mm)
Number of bars	3 Pieces	2 Pieces	1 piece

IMPORTANT -- Do not try to bend materials that exceed the maximum diameter of bar, or it will cause either the motor to burn out or a machine failure.

- The machine will only operate on the voltage for which it is designed (with a tolerance of 10%). 115 Volt, 50/60 Hz, 10 amps, 1050 watts
- To avoid electrical shock, do not handle with wet hands or use in a damp place.



BN Products-USA, LLC

3450 Sabin Brown Road • Wickenburg, Arizona 85390

(800) 992-3833 • (928) 684-2813 • www.bnproducts.com

General Safety Rules

WARNING: Read all instructions. Failure to follow all instructions listed below may result in electric shock, fire and/or serious injury. The term “power tool” in all of the warnings listed below refers to your mains-operated (corded) power tool or battery-operated (cordless) power tool.

SAVE THESE INSTRUCTIONS

Work area safety

- Keep work area clean and well lit. Cluttered or dark areas invite accidents.
- Do not operate power tools in explosive atmospheres, such as in the presence of flammable liquids, gases or dust. Power tools create sparks which may ignite the dust or fumes.
- Keep children and bystanders away while operating a power tool. Distractions can cause you to lose control.

Electrical safety

- Power tool plugs must match the outlet. Never modify the plug in any way. Do not use any adapter plugs with earthed (grounded) power tools. Unmodified plugs and matching outlets will reduce risk of electric shock.
- Avoid body contact with earthed or grounded surfaces such as pipes, radiators, ranges and refrigerators. There is an increased risk of electric shock if your body is earthed or grounded.
- Do not expose power tools to rain or wet conditions. Water entering a power tool will increase the risk of electric shock.
- Do not abuse the cord. Never use the cord for carrying, pulling or unplugging the power tool. Keep cord away from heat, oil sharp edges or moving parts. Damaged or entangled cords increase the risk of electric shock.
- When operating a power tool outdoors, use an extension cord suitable to outdoor use. Use a cord suitable for outdoor use reduces the risk of electric shock.



BN Products-USA, LLC

3450 Sabin Brown Road • Wickenburg, Arizona 85390

(800) 992-3833 • (928) 684-2813 • www.bnproducts.com

Personal safety

- Keep hands and fingers away. From all moving parts, cutting blocks and rollers while operating these power tools.
- Stay alert, watch what you are doing and use common sense when operating a power tool. Do not use a power tool while you are tired or under the influence of drugs, alcohol or medication. A moment of inattention while operating power tools may result in serious personal injury.
- Use safety equipment. Always wear eye protection. Safety equipment such as dust mask, non-skid safety shoes, hard hat, or hearing protection used for appropriate conditions will reduce personal injuries.
- Avoid accidental starting. Ensure the switch is in the off-position before plugging in. Carrying power tools with your finger on the switch or plugging in power tools that have the switch on invites accidents.
- Remove any adjusting key or wrench before turning the power tool on. A wrench or a key left attached to a rotating part of the power tool may result in personal injury.
- Do not overreach. Keep proper footing and balance at all times. This enables better control of the power tool in unexpected situations.
- Dress properly. Do not wear loose clothing or jewelry. Keep your hair, clothing and gloves away from moving parts. Loose clothes, jewelry or long hair can be caught in moving parts.
- If devices are provided for the connection of dust extraction and collection facilities, ensure these are connected and properly used. Use of these devices can reduce dust-related hazards.

Power tool use and care

- Do not exceed the maximum number of bars that can be bent and or cut at one time. Refer to additional information contained in these instructions.
- When positioning the bar between the bending rollers or cutting blocks, make sure to lay it flat on the machine surface. Refer to additional information contained in these instructions.



BN Products-USA, LLC

3450 Sabin Brown Road • Wickenburg, Arizona 85390

(800) 992-3833 • (928) 684-2813 • www.bnproducts.com

- Do not cut or bend materials harder than and or other than “Grade 60 or 420MPa” re-bar. As they will either crack or fly out or cause machine failure.
- Do not force the power tool. Use the correct power tool for your application. The correct power tool will do the job better and safer at the rate for which it was designed
- Do not use the power tool if the switch does not turn it on and off. Any power tool that cannot be controlled with the switch is dangerous and must be repaired.
- Disconnect the plug from the power source and/or the battery pack from the power tool before making any adjustments, changing accessories, or storing power tools. Such preventative safety measures reduce the risk of starting the power tool accidentally.
- Store idle power tools out of the reach of children and do not allow persons unfamiliar with the power tools or these instructions to operate the power tool. Power tools are dangerous in the hands of untrained users.
- Maintain power tools. Check for misalignment or binding or moving parts, breakage of parts and any other condition that may affect the power tools operation. If damaged, have the power tool repaired before use. Many accidents are caused by poorly maintained power tools.
- Keep cutting tools sharp and clean. Properly maintained cutting tools with sharp cutting edges are less likely to bind and are easier to control.
- Use the power tool, accessories and tool bits etc., in accordance with these instructions and in the manner intended for the particular type of power tool, taking into account the working conditions and the work to be performed. Use of the power tool for operations different from those intended could result in a hazardous situation.

Service

- Have your power tool serviced by a qualified repair person using only identical replacement parts. This will ensure that the safety of the power tool is maintained.
- Keep tool clean at all times for best and safest performance. Follow these instructions for lubricating and changing parts. Keep hands dry and free of oil or grease. Inspect switches, tool cords periodically and have them repaired or replaced by an authorized service center if damaged. Check moving parts for alignment and binding as well as for breakage and improper mounting. Damaged parts should be repaired or replaced by an authorized service facility.



BN Products-USA, LLC

3450 Sabin Brown Road • Wickenburg, Arizona 85390

(800) 992-3833 • (928) 684-2813 • www.bnproducts.com

Operating the HB-16W Rebar Bender

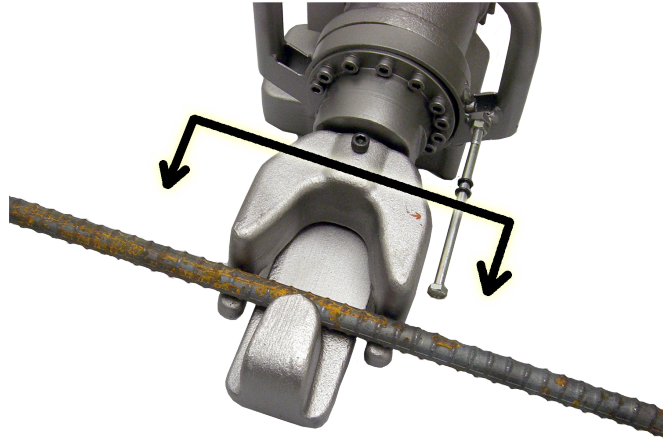

Insert rebar(s) in between the pivot shoe and housing so that the rebar is at right angles to the pivot shoe/housing.



Throttle the on/off switch until the rebar has reached your required angle.

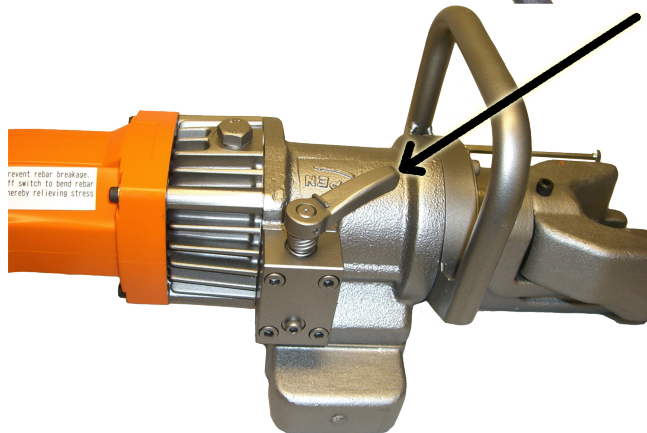

After the bend, release the on/off switch and turn the valve lever to the open position to return the piston to the starting position. The piston will not return automatically when the on/off switch is released.



BN Products-USA, LLC

3450 Sabin Brown Road • Wickenburg, Arizona 85390

(800) 992-3833 • (928) 684-2813 • www.bnproducts.com

HB-16W Rebar Bender Maintenance

OIL CHECK: The HB-16W is hydraulically operated. It is therefore necessary to check the oil level at frequent intervals, preferably every day. If oil level is too low, power will drop and the piston will not move properly.

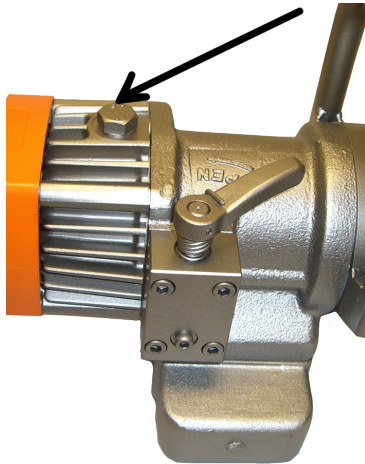

- Extend the piston to the fullest extent of its stroke.
- Remove oil plug bolt. Only remove the plug when the unit is cool (if it is hot, oil may spurt out suddenly.)
- The pump case should be full to the brim. If the level is low, top up with Texaco Rando HD 68 hydraulic oil or equivalents. This is a 20-weight hydraulic oil with anti-foam and anti-abrasion properties. **Do not use any other oil.**
- It is imperative that there be no air in the system. After topping up, gently tilt the unit and return the tool to the level position. Top up again and tilt in the opposite direction. Repeat this process until all air has been extracted. (This is a rather lengthy process, but it is essential to proper functioning on the unit.)

OPERATING TEMPERATURE: Do not allow the unit to overheat. If the oil temperature exceeds 70 degrees Centigrade or 158 degrees Fahrenheit, the piston speed will fall and the unit should be allowed to cool down before being used again.

Optional Shoe and Collar for HB-16W Portable #5 Rebar Bender

Optional 90 degree Bending Shoe (IHB16041A)
and Larger Radius Bending Collar (IHB3107800)

How to install 90 degree Bending Shoe and Larger Radius Bending Collar:

1. Simply remove the (#8) bending angle marker and (#9) standard 0-135 degree pivot shoe (refer to HB-16W handling instructions).
2. Attach 90 degree bending shoe to piston/ring and tighten cap bolt.
3. Slide larger radius bending collar over housing bending horn and tighten cap bolt (this will minimize breakage on grade 60 rebar).
4. Place rebar flat and level between shoe and collar before starting bend.
5. Pull the (#3) on/off switch until the piston/shoe cannot extend any further, once the rebar is bent to 90 degree; do not continue to keep the switch in the "on" position and the motor running because this will cause internal tool damage.
6. After completing bend immediately switch "off" and retract (#5) valve lever, remove bent rebar and repeat this process.

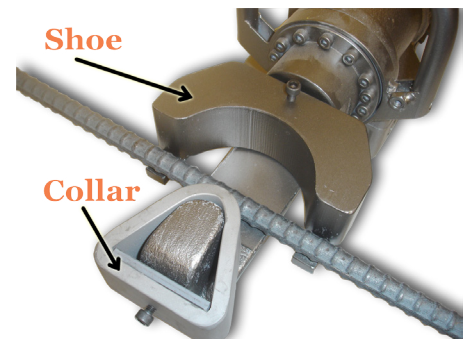



BN Products-USA, LLC

3450 Sabin Brown Road • Wickenburg, Arizona 85390

(800) 992-3833 • (928) 684-2813 • www.bnproducts.com

More Portable Rebar Benders from BN Product-USA



The MBC-16B Manual Bender/Cutter

This is a manual tool that has been designed to bend and cut rebar up to #5 (5/8") grade 60. This new high-leverage arrangement greatly reduces cutting and bending effort. The tool comes complete with a wood mounting board. An adjustable 2.5" diameter bender roller provides true 90 and 180 degree bends. Replaceable cutting jaws have two open slots with innovative shaped blades to prevent chipping. This tool has a 6 month warranty and pre-paid freight on orders of 6 or more to one location.



DBD-16X Portable #5 Rebar Bender

This heavy-duty tool will bend rebar up to #5 (5/8") grade 60 at the job site or in your shop. This strong electrical-mechanical bender has two preset angle locks for repeating the same angle bend. The dial-type angle selector can be set to accurately bend any angle from 0-180 degrees. It has an emergency stop switch and two side lifting handles that are standard features. Ships complete with set of (6) bending rollers in a steel carrying case, a tool kit, and a standard foot pedal control switch for hands-free bending.

DBD-20X Portable #6 Rebar Bender



This professional portable rebar bender helps save valuable man-hours by bending rebar up to #6 (3/4") grade 60 at the job site or in your shop. This bender has two preset angle locks for repeating the same angle bend. The dial-type angle selector can be set to accurately bend any angle from 0-180 degrees. An emergency stop switch and two side lifting handles are standard features and comes complete with set of (6) bending rollers, a tool kit, and a standard foot pedal control switch for hands-free bending.

DBD-25X Portable #7 Rebar Bender



This heavy-duty portable rebar bender helps save valuable man-hours by bending rebar up to #7 (7/8") grade 60 at the job site or in your shop. This bender meets ACI 318-05 rebar bending specifications on #4, #5 & #6 rebar only. The lever-type angle selector can be set to accurately bend any angle from 0-180 degrees. It has an emergency stop switch and two lifting handles that are standard features. The bender comes complete with a set of (6) bending rollers, a tool kit and a standard foot pedal control switch for hands-free bending.

DBD-25H Portable #8 Rebar Bender



This heavy-duty portable bender will effortlessly bend rebar up to #8 (1") Grade 60 at job sites or in your shop. This electrical-mechanical bender has two preset angle locks for repeating the same angle bend. The lever-type angle selector can be set to accurately bend any angle from 0-180 degrees. Meets ACI 318-05 bending specifications. This tool comes complete with (9) bending rollers in steel carrying cases, a tool kit, a bender cover, and a standard foot pedal control switch for hands-free bending.

DBD-32X Portable #9 Rebar Bender



This is a professional heavy-duty portable table-type bender. This unit is the largest 115V portable rebar bender available. This tool will easily bend 1-1/8" Grade 60 rebar 180 degrees in only 8 seconds. It's fast and accurate bending makes it a valuable tool for small to medium size production shops. It comes standard with a hands-free foot pedal control switch and a complete bending radius roller set.



BN Products-USA, LLC

3450 Sabin Brown Road • Wickenburg, Arizona 85390
(800) 992-3833 • (928) 684-2813 • www.bnproducts.com

HB-16W Rebar Bender Parts Manual





BN Products-USA, LLC

3450 Sabin Brown Road • Wickenburg, Arizona 85390

(800) 992-3833 • (928) 684-2813 • www.bnproducts.com

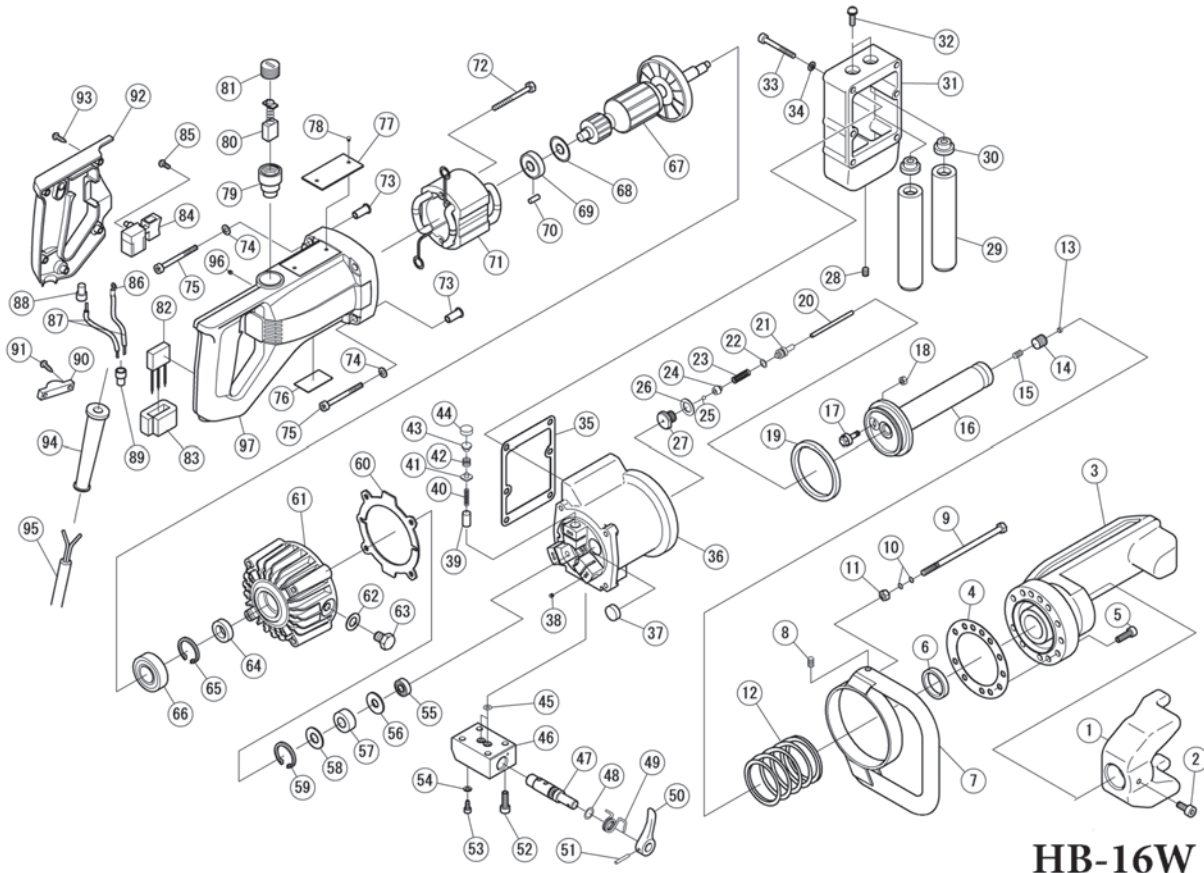

HB-16W

No.	Part No.	Part Name	Qty
1	1HB16041	BENDING SHOE	1
2	7CB06010	CAP BOLT M6×10	1
3	1HB1603A	HOUSING	1
4	1HB261	CYLINDRE PACKING	1
5	7CB06028	CAP BOLT M6×28	12
6	3P1031	SEAL PACKING	1
7	1DBR29481	HANDLE	1
8	7SS06012	SET SCREW M6×12	1
9	7B06120	SET BAR M6×120	1
10	70RP5	O RING P5	2
11	7UN0006	U NUT M6	1

No.	Part No.	Part Name	Qty
12	1HB205	RETURN SPRING	1
13	1HB1620	RUBBER PLUG	1
14	7PT1/8	PLUG PT1/8	1
15	7SS06012	SET SCREW M6×12	1
16	1HB16012	PISTON	1
17	1HB2032	RETURN VALVE	1
18	7N0005	NUT M5	1
19	1C1318	SEAL PACKING	1
20	1HB16051	ADJUST ROD	1
21	1DBR2939	SPRING GUIDE	1
22	1DBR2945	O RING P7	1



BN Products-USA, LLC

3450 Sabin Brown Road • Wickenburg, Arizona 85390

(800) 992-3833 • (928) 684-2813 • www.bnproducts.com

No.	Part No.	Part Name	Qty
23	1DBR2942	SAFETY VALVE SPRING	1
24	1DBR2938	VALVE SET	1
25	1DBR2943	STEEL BALL 5/32	1
26	1DBR2944	SEAL WASHER WF12	1
27	1DBR2941	SAFETY VALVE SEAT	1
28	7PT1/8	PLUG PT1/8	1
29	1C2570	AIR BAG	2
30	1CM2027	AIR BAG NUT	2
31	1HB207A	AIR BAG COVER	1
32	1C1357	AIR BAG SET BPOL	2
33	7CB06050	CAP BOLT M6×50	6
34	7SW0006	SPRING WASHER M6	6
35	1HB208	AIR BAG COVER PACKING	1
36	1HB201B	CYLINDER	1
37	3P1044	MAGNET FILTER	3
38	7SS04004	SET SCREW M4×4	6
39	1C1327	RAM	3
40	1C1330	RAM RETURN SPRING	3
41	1C13281	DELIVERY VALVE	3
42	1C1331	DELIVERY VALVE SPRING	3
43	1C13352	SPRING GUIDE	3
44	1C13292	PUMP HEAD SEAL	3
45	1HB1630	O RING P-6	2
46	1DBR2925	VALVE CASE	1
47	1DBR2921	ROTARY VALVE	1
48	1DBR2946	O RING P10A	1
49	1DBR2923	VALVE LEVER SPRING	1
50	1DBR2922	VALVE LEVER	1
51	1HB303	SPRING PIN Φ3×20	1
52	7CB06030	CAP BOLT M6×30	4
53	1DBR5012	BOLT M5×12	1
54	1HB1631	SEAL WASHER W5	1
55	1CW0003	BALL BEARING 698	1
56	1C1325	BEARING GUIDE	1
57	1C13401	NEEDLE BEARING	1
58	1C1325	BEARING GUIDE	1
59	1C1326	SNAP RING HR27	1
60	1C1615	PUMP CASE PACKING	1

No.	Part No.	Part Name	Qty
61	4V0001A	PUMP CASE	1
62	1C1305	SEAL WASHER WF10	1
63	7B10015	OIL PLUG	1
64	7SD15257	OIL SEAL	1
65	7HR26	SNAP RING H26	1
66	76002VV	BALL BEARING 6002VV	1
67	4V0001B	ARMATURE WITH CAM	1
68	4V0001J	DUST SEAL A	1
69	7608VV	BALL BEARING 608VV	1
70	4V0001G	BEARING LOCK	1
71	4V0001C	STATOR COIL	1
72	7WNS05060	TAPPING SCREW D5×60	2
73	4V0001K	SLEEVE	4
74	7PW0005	PLATE WASHER M5	4
75	7CB05080	CAP BOLT M5×80	4
76		STICKER	1
77		NAME PLATE	1
78		RIVET	2
79	4V0001D	BRUSH HOLDER	2
80	4V0001F	CARBON BRUSH SET	1
81	4V0001E	BRUSH CAP	2
82	4V0001P	CONDENSER	1
83	4V0001Q	SUPPORT B	1
84	4V0001N	SWITCH	1
85	7WB035006	SCREW 3.5×6	2
86	4V0001S	TERMINAL	1
87	4V0001T	LEAD WIRE	1
88	4V0001W	CONNECTOR 50092	1
89	4V0001U	CONNECTOR 50091	1
90	4V0001R	CORD CLIP	1
91	7FNS04016	TAPPING SCREW 4×16	2
92	4V0001M	SWITCH COVER	1
93	7WNS04020	TAPPING SCREW 4×20	5
94	4V0001X	CORD ARMER	1
95	4V0001V	CORD SET	1
96	7SS04005	SET SCREW 4×5	2
97	4V0001H	MOTOR HOUSING	1



BN Products-USA, LLC

3450 Sabin Brown Road • Wickenburg, Arizona 85390
(800) 992-3833 • (928) 684-2813 • www.bnproducts.com

