



BN Products-USA, LLC.

3450 Sabin Brown Road • Wickenburg, AZ 85390
(800) 992-3833 • (928) 684-2813 • mail@bnproducts.com



DBR – 25WH

**REBAR STRAIGHTENER
HANDLING INSTRUCTIONS**

**READ THESE INSTRUCTIONS CAREFULLY BEFORE
ATTEMPTING TO USE REBAR STRAIGHTENER**

Not following proper operating procedures can lead to accidents.
If in doubt of any procedure, contact your local authorized agent.

The DBR-25WH is a portable heavy-duty electric/hydraulic rebar bender and straightener. It helps save valuable man-hours by cleanly and efficiently bending or straightening bent rebar. It functions as a simple 90-degree portable electric rebar bender. The interchangeable bending hook covers rebar diameters from #4 to #8 grade 60. Maximum pressure for bending and straightening ranges from 8.5 to 11 tons. It's portable and versatile enough to bend or straighten rebar in-place with its push/pull hydraulic capabilities. It will bend a 90-degree angle in only (4) seconds. The bending head also rotates 360 degrees. Ships complete in a wooden carrying case with hydraulic oil, a tool kit and two additional bending dies. This tool solves bending applications other tools can't even attempt.



BN Products-USA, LLC.

3450 Sabin Brown Road • Wickenburg, AZ 85390
 (800) 992-3833 • (928) 684-2813 • mail@bnproducts.com

GENERAL SAFETY PRECAUTIONS

Application: Use DBR-25WH on concrete re-enforcing bars only.

RESTRICT USE TO DESIGNATE MATERIALS

There is always a chance that the end of material may break and shoot out, especially if the material is harder than those specified. Exceeding designated material specifications greatly increase this risk and will also damage the tool. Do not attempt to use the tool for rebar harder, thicker, or thinner than those specified.

USE EYE PROTECTION

Wear safety goggles, safety glasses with side shields or a face shield when using the rebar straightener.

KEEP HANDS AWAY

Do not touch rebar, housing, hook, rollers, and/or the piston while rebar straightener is being operated.

GUARD AGAINST ELECTRIC SHOCK

To avoid possible electric shock, do not handle the DBR-25WH with wet hands, or use in the rain or other damp places. Be aware of all power lines, electric circuit and other hazards that may be contacted, especially those that are below the surface or otherwise hidden from view.

UNPLUG TOOL

Disconnect the tool from outlet when not in use and before cleaning, adjusting, or servicing. Do not disconnect plug from outlet by pulling on the cord. Always check that the switch lock is OFF before plugging your tool in.

BEWARE OF YOUR ENVIRONMENT

Do not use rebar straightener in the presence of flammable materials (e.g., paint, thinner, petroleum products, and adhesives.) Do not use rebar straightener in a possibly explosive environment, (e.g., fumes, gas, or dust) or in areas that are poorly ventilated.

KEEP WORK AREA TIDY AND WELL LIT

Make sure that work area is properly lighted and clear of obstructions. Operator should at all times have an unobstructed view of their rebar straightener, rebar, and the surrounding area.

WEAR PROPER APPAREL

Do not wear loose clothes, dangling objects, or jewelry. Restrain long hair. The use of a safety helmet and rubber soled boots are strongly recommended. If safety gloves are worn, be especially careful that gloves do not get caught in the moving parts.

KEEP VISITORS AWAY

Keep all visitors at a safe distance from the work area for their own protection and to prevent distraction of the operator.

Max Rebar Diameter	25 mm			
Straightening	Max yield point 345N/mm ²			
Bending	Max yield point 295N/mm ²			
Rebar Diameter	Straightening Capacity		Bending Capacity	
	Push	Pull	Push	Pull
13 mm	up to 125°	up to 121°	up to 94°	up to 92°
16 mm	128	124	90	90
20 mm	130	126	90	90
25 mm	132	124	90	90
Max pressure	11 Tons	8.5 tons	11 tons	8.5 tons
Output	1.5 HP			
Weight	22.5 Kg			
Dimension	660x270x200mm (LxWxH)			



BN Products-USA, LLC.

3450 Sabin Brown Road • Wickenburg, AZ 85390
(800) 992-3833 • (928) 684-2813 • mail@bnproducts.com

MAINTAIN REBAR STRAIGHTENER WITH CARE

Inspect rebar straightener before each use. Faulty or loose bending hook could possibly result in personal injury. Keep handle dry, clean and free from oil and/or grease. Keep housing and piston free of dirt and iron filings. Check that no screws or bolts are loose or missing. Follow all instructions for maintenance. Inspect switch, cord, plug and any extension cable at regular intervals.

STORE CAREFULLY

When not in use, store rebar straightener and its accessories in a dry place where they cannot be accessed by anyone but the operators.

PARTS AND SPECIFICATIONS (Figure 1)

1. Handle
2. Switch
3. Mode control lever
4. Oil plug
5. Front handle
6. Hook
7. Roller
8. Housing
9. Motor

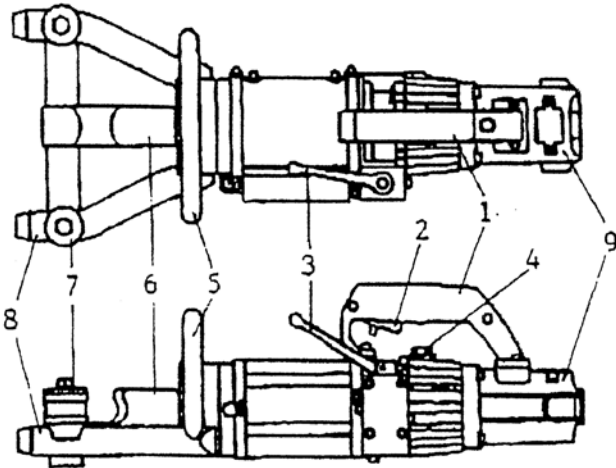

OPERATING INSTRUCTIONS

Check the oil level.

Check that the power source is appropriate to the rebar straightener.

CARE- If voltage is too high, the motor will burn out, if voltage is too low, insufficient power will be generated.

NEVER USE DC CURRENT OR AC HIGHER THAN 110V

Check that the power supply is properly earthed.

CAUTION- Failure to properly earth the power supply may result in a shock to the operator.

Check that the cord is undamaged and that the plug is not loose.

CAUTION- Cut or abraded covering could result in a short and electric shock to the operator.

If an extension cord is to be used, make sure that it is undamaged and that it is the proper thickness for the length. See table below.

	100/115V	230V
Cable Length	Cable Size (AWG)	Nominal Diameter
Up to 10m (33 ft.)	16	1.0mm ²
Up to 15m (50 st.)	14	1.25mm ²
Up to 30m (100ft.)	10	1.5mm ²

Before plugging the tool in, make sure that the switch lock is off.

CAUTION- If switch lock is ON; the rebar straightener will start as soon as it is plugged in. To disengage lock, pull the trigger switch, the lock button will pop out.

WARM UP

In cold weather, warm up the unit for 30-60 seconds so that the hydraulic oil will reach the proper viscosity. Pull the trigger switch to extend the piston and release when it has reached its full stroke. Repeat this action 3-5 times.

POINTS OF ATTENTION

1. Do not cover air vents.
2. **CARE-** If vents are covered, the motor will overheat and may burn out.



BN Products-USA, LLC.

3450 Sabin Brown Road • Wickenburg, AZ 85390
(800) 992-3833 • (928) 684-2813 • mail@bnproducts.com

3. If hydraulic oil exceeds 70°C, (158°F) the power will drop. Allow the unit to cool before resuming operation. (Be particularly careful in summer, when the aluminum pumpcase heats up quicker.)
4. If a drop in power is observed and motor is unusually hot, check the carbon brushes.

OPERATION

The DBR-25WH is primarily intended to straighten deformed rebar. It can, of course, also be used to bend straight rebar.

To enable the unit to be used in confined spaces, there are two operating modes: Push & Pull. The mode is selected by moving the mode control lever to the appropriate position.

“A” for push (piston advances) and “B” for pull (piston retracts) In either mode, simply press the switch to move the piston.

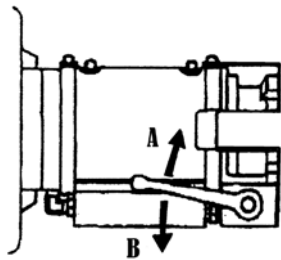

NB: The movement of the piston is limited by a safety valve. To prevent overheating, release the trigger switch when the piston has reached its travel limit.

TO PUSH

Advance or retract the piston so that the hook is in a suitable starting position. Set the mode control lever to “A” and fit the rebar as shown at the left. Pull the trigger switch until the rebar is at the desired angle.

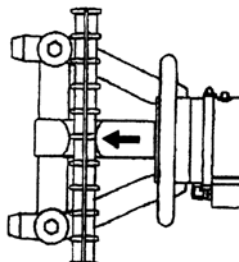

TO PULL

Set the hook in the correct starting position, make sure that the mode control lever is in the “B” position and fit the rebar as illustrated. Pull the trigger switch until the desired angle is attained.

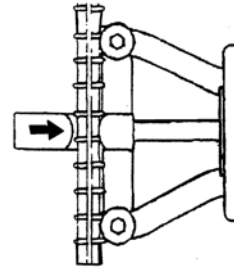

NB: It is important that the rebar be properly fitted in the hook and against the rollers.

INTERIOR ANGLE

Since the piston stroke is limited, interior straightening / bending angle will vary according to rebar diameter and operating mode. Refer to the table below.

CLEANING

Clean rebar straightener everyday, preferably immediately after use.

CAUTION- Wear gloves to protect hands from metal splinters. Do not use air guns – Blasting with air guns can cause metal filings and/or dust to get into eyes and respiratory system.

1. Disconnect unit.
2. Wipe or brush away all dirt and metal filings. Pay particular attention to the lower half of the piston, where dirt is more easily accumulated.
3. Once the piston has been retracted, pull the trigger switch long enough to partially unplug unit. Check the piston for accumulated dirt and iron filings that may be jamming the piston.

OIL LEVEL CHECK

As rebar straightener is hydraulically operated, the oil level must be checked at frequent intervals, preferably everyday. Failure to maintain the oil at proper levels will result in a drop in pressure and loss of the benders hydraulic power.



BN Products-USA, LLC.

3450 Sabin Brown Road • Wickenburg, AZ 85390
(800) 992-3833 • (928) 684-2813 • mail@bnproducts.com

CAUTION- Hydraulic oil is highly flammable. Keep away from sparks and naked flame. **DO NOT SMOKE WHEN NEAR OIL/BENDER.**

CAUTION- Hydraulic oil may cause inflammation of the eyes and skin. If ingested, it will cause diarrhea and vomiting.

In case of eye contact, rinse in clean water for at least 15 minutes and consult a physician immediately, as blindness can occur.

In case of skin contact, wash thoroughly with soap and water.

In case of ingestion, consult a physician immediately. **DO NOT DELIBERATELY INDUCE VOMITING.**

OIL MAINTENANCE CON'T.

1. Oil should be warm, but not hot. Warm up the unit if cold.
2. Unplug unit from the power source.
3. Remove oil plug and the seal washer (packing)
4. CAUTION- Never remove oil plug when unit is hot, as the oil may spurt over.
5. Check that oil is level with the bottom of the plug hole (i.e. the pump case is full to the brim) If oil level is too low, top up with 20- weight hydraulic oil with anti-foam and anti- abrasion properties (ISO viscosity grade VG46, e.g., Shell Tellus 46, Mobil Oil DTE-25, or Esso Uni Power SQ46)
6. After topping up, extract air from the system. Gently tilt the unit and return it to the level position. Top up again and tilt in the opposite direction. Repeat this action until all air has been removed.
7. CARE- Rebar straightener cannot function properly if oil contains air bubbles.
8. Replace seal washer and plug. Extend to its full stroke, and remove oil plug and seal washer. Then repeat the procedure of above
9. Replace the oil plug and seal washer.

OIL CHANGE

The hydraulic oil should be changed at least once a year, sooner if it appears to be dirty.

1. Unplug the unit from the power source. Remove the

- oil plug and packing. Turn the unit over and drain oil into an appropriate receptacle.
2. With drain hole uppermost, slowly fill the unit with fresh oil. Replace plug and lightly tighten. Connect the unit to power source and advance piston two or three times. Unplug the unit and remove the oil plug. Top up the oil level and replace plug.
3. Finally, follow procedure for oil level check.

Please dispose of any hydraulic oil in accordance with local regulations. Do not pour into sea, a river, lake or drains.

BOLT TIGHTNESS

Once a week, or after every 30 times use, check the tightness of all bolts, especially those securing the housing to the cylinder.

CARBON BRUSHES

Inspect the two carbon brushes at least every two months. (Normal brush life is around 200 hours. CARE- Worn carbon brushes will result in power loss, cause the motor to run hot and irreparably damaging the armature's commutator.

1. Disconnect unit.
2. Unscrew both brush caps and pull out the carbon brushes.
3. Replace the brushes if less than 6MM in length.

OVERHAUL

Return the unit to an authorized agent for overhaul at least once every two years, sooner if subject to heavy usage.



BN Products-USA, LLC.

3450 Sabin Brown Road
Wickenburg, AZ 85390
(800) 992-3833
(928) 684-2813
Fax: (928) 684-7041
mail@bnproducts.com
bnrebartools.com



BN Products-USA, LLC.

3450 Sabin Brown Road • Wickenburg, AZ 85390
 (800) 992-3833 • (928) 684-2813 • mail@bnproducts.com

DBR-25WH

Portable #8 Rebar Bender

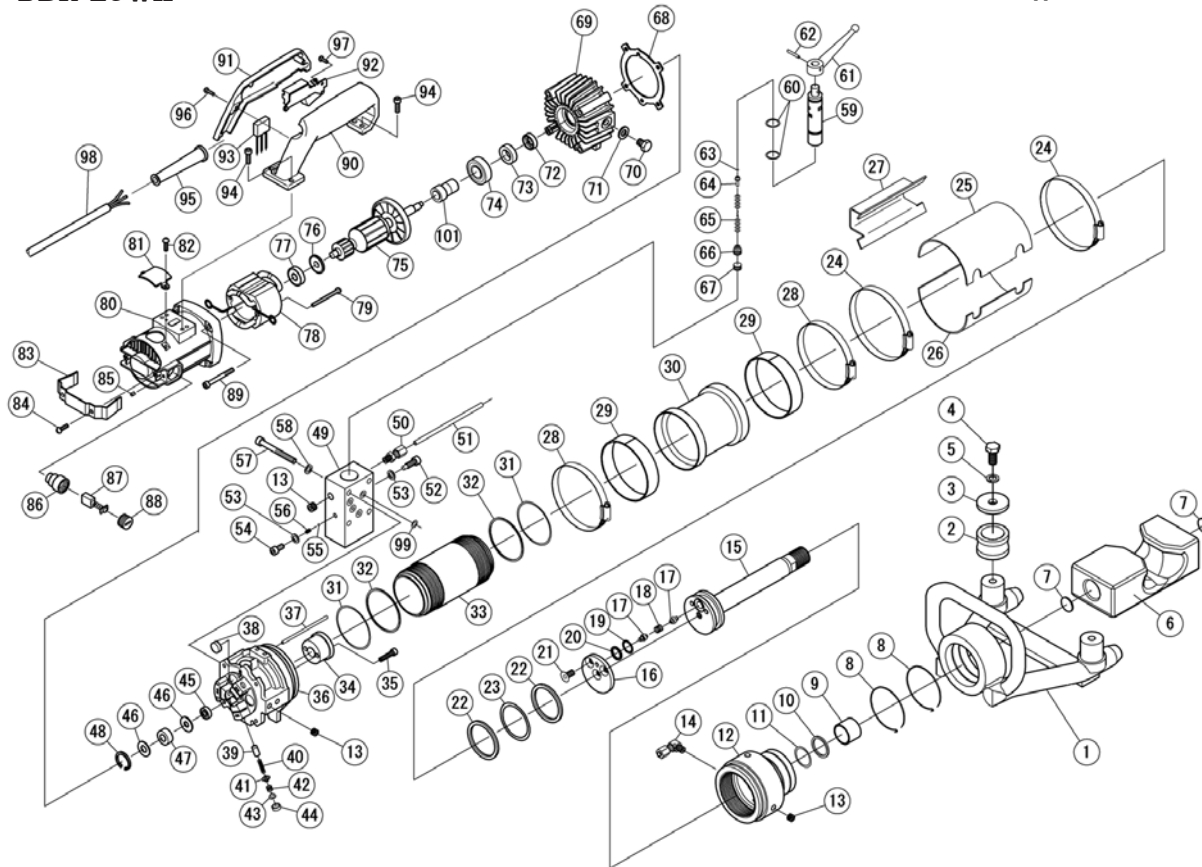

No.	Part No.	Part Name	Qty
1	1DBR20579A	HOUSING	1
2	1DBR72	ROLLER	2
3	1DBR73	ROLLER CLAMP	2
4	7B12025	HEX.BOLT M12x25	2
5	7SW0012	SPRING WASHER M12	2
6	1DBR80A	HOOK	1
7	1DBR711	PACKING	2
8	1DBR309550	HOLDING WIRE	2
9	7MB3025DU	DRY BUSH	1
10	7BRP30	BACK-UP RING P30	1
11	7ORP30	O RING P30	1
12	1DBR309540	HOUSING GUIDE	1
13	7PT1/8	PLUG PT1/8	4
14	3DS2359	ELBOW NIPPLE	1
15	1DBR562	PISTON	1

No.	Part No.	Part Name	Qty
16	1DBR581	VALVE COVER	1
17	1DBR57	END VALVE	2
18	1C1922	VALVE END SPRING	1
19	7ORP14	O RING P14	1
20	1DBR83	BACK-UP RING	1
21	7DS08016	DISK SCREW M8x16	3
22	7BRP55	BACK-UP RING P55	2
23	7ORP55	O RING P55	1
24	1DBR20B	HOSE BAND ϕ 120	2
25	1DBR66	COVER A	1
26	1DBR67	COVER B	1
27	1DBR682	PIPE COVER	1
28	1DBR20A	HOSE BAND ϕ 100	2
29	1DBR79	BAND PACKING	2
30	1DBR64	AIR BAG	1



BN Products-USA, LLC.

3450 Sabin Brown Road • Wickenburg, AZ 85390

(800) 992-3833 • (928) 684-2813 • mail@bnproducts.com

No.	Part No.	Part Name	Qty
31	7ORG70	O RING G70	2
32	7BRG70E	BACK-UP RING G70	2
33	1DBR55	PIPE CYLINDER	1
34	1DBR54	STOPPER	1
35	7CB06030	CAP BOLT M6x30	2
36	1DBR511WH	CYLINDER	1
37	1DBR63	TUBE 4x2.5	1
38	3P1044	MAGNET FILTER	3
39	1C1971	RAM	3
40	1C1972	RAM RETURN SPRING	3
41	1C1973	DELIVERY VALVE	3
42	1C1331	DELIVERY VALVE SPRING	3
43	1C13352	SPRING GUIDE	3
44	1C13292	PUMP HEAD SEAL	3
45	1CW0003	BALL BEARING 698	1
46	1C1325	BEARING GIDE	2
47	1C1340	NEEDLR BEARING RNAST8	1
48	1C1326	SNAP RING H27	1
49	1DBR75	VALVE CASE	1
50	3DS2360	CONNECTOR	1
51	1DBR62	OIL PIPE	1
52	1DBR77	GUIDE BOLT	1
53	3DS2026	7DS1H6 SEAL WASHER	2
54	7CB06006	CAP BOLT M6x6	1
55	7SB3/16	STEEL BALL 3/16	1
56	3DA102K	STOPPER SPRING	1
57	7CB06040	CAP BOLT M6x40	4
58	7SW0006	SPRING WASHER M6	4
59	3DS23322	ROTARY VALVE	1
60	7ORP18	O RING P18	2
61	1DBR531	VALVE LEVER	1
62	7SP420	SPRING PIN ϕ 4x20	1
63	7SB5/32	STEEL BALL 5/32	1
64	1DBR821	VALVE SET	1

No.	Part No.	Part Name	Qty
65	7BSH4	DISK SPRING	24
66	1DBR84	GUIDE BOLT	1
67	7SS12012	SET SCREW M12x12	1
68	1C1951B	PUMP CASE PACKING	1
69	3DS1939B	PUMP CASE	1
70	7B10015	OIL PLUG M10x15	1
71	1C1305	SEAL WASHER WF10	1
72	3DS2025	SEAL COVER	1
73	3DS2009	OIL SEAL TCV17358	1
74	1C1941	BALL BEARING 6004VV	1
75	1C1963EW	ARMATURE WITH CAM	1
77	760002RU	BALL BEARING 6000VV	1
78	1C1963D	STATOR COIL	1
79	7P205055	PAN HEAD BOLT M5x55	2
80	1C1961K	MOTOR HOUSING	1
81	7971055	SIDE COVER	1
82	7P204008	PAN HEAD BOLT M4X8	2
83	1C1961S	TAIL COVER	1
84	7P205010	PAN HEAD BOLT M5x10	2
85	7SS05008	SET SCREW 5x8	2
86	1C1961J	BRUSH HOLDER	2
87	1C1961A	CARBON BRUSH SET	2
88	1C1961H	BRUSH CAP	2
89	7CB06090	CAP BOLT M6x90	4
90	1C1944B/C	MAIN HANDLE	1
91	1C1946	SWITCH COVER	1
92	1C1961B	SWITCH	1
93	1CL001N	CONDENSER	1
94	7CB06018	CAP BOLT M6x18	4
95	1BR5012G	CORD ARMER	1
96	7PB04015	PAN HEAD BOLT M4X15	2
97	7PB04008	PAN HEAD BOLT M4X8	2
98	1C1961F	CORD SET	1
99	1DBR2945	O RING P7	4

Maximum Bending Diameter	1" #8 Rebar (25mm) Grade 60
Bending Angle	Up to 94 degrees (1/2") - up to 90 degrees (1")
Voltage/ Amperage	115V 50/60Hz / 12 amps
Tool Weight	57.3 lbs (26 kg)
Dimensions L x W x H	25.75" (660mm) x 10.5" (270mm) x 7.8" (200mm)



BN Products-USA, LLC.

3450 Sabin Brown Road • Wickenburg, AZ 85390
 (800) 992-3833 • (928) 684-2813 • mail@bnproducts.com

DBR-25WH Dies and Hook Bending Radiuses Standard with DBR-25WH Bender/Straightener

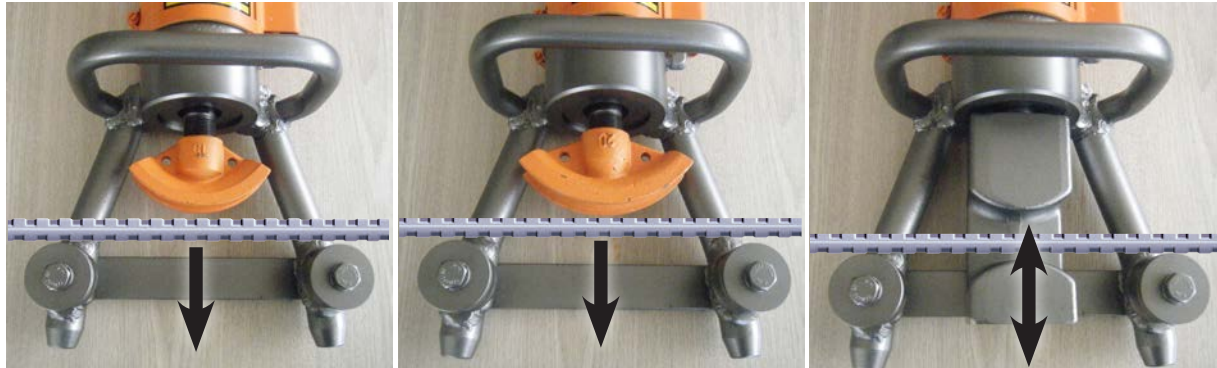

#15 Bend Die	#20 Bend Die	1DBR80A Bend Hook
M16 x D7 Female Threads on one end	M16 x D7 Female Threads on one end	M16 x D7 Female Threads on both ends
Marked: 1/2" & 15	Marked with: 3/4" & 20	Marked with: *NA
With this bending die push/bend forward only	With this bending die push/bend forward only	With this bending hook push/bend forward & pull/bend backwards or straighten rebar
4.5" Bend Radius	6" Bend Radius	3.75" Bend Radius
ACI Approved Bend for #6 Rebar (19mm)	ACI Approved Bend for #8 Rebar (25 mm)	ACI Approved Bend for #5 Rebar (16 mm)

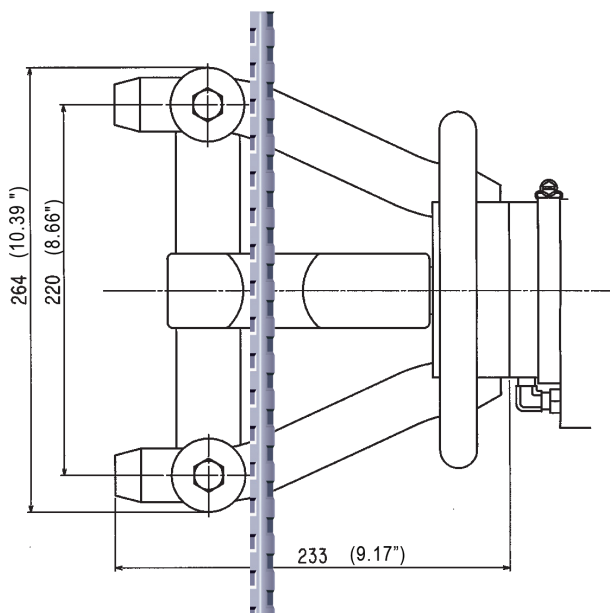

Special order #25 bend die available upon request.

NA – Not Available, No Markings

Notes: For In-place bending applications the bending head pictured to the left needs to be raised at least 1.5" off the surface of the concrete in order to make a complete 90 degree bend. The minimum height above the concrete surface in which a bend can be made is 6" or 152.5 mm.