



BN Products-USA™

A DIVISION OF BENNER-NAWMAN, INC.

DBC-16H
#5 REBAR BENDER / CUTTER
OPERATOR MANUAL

DBC-16H

Portable Electric #5 (16mm) Combination Rebar Bender and Rebar Cutter

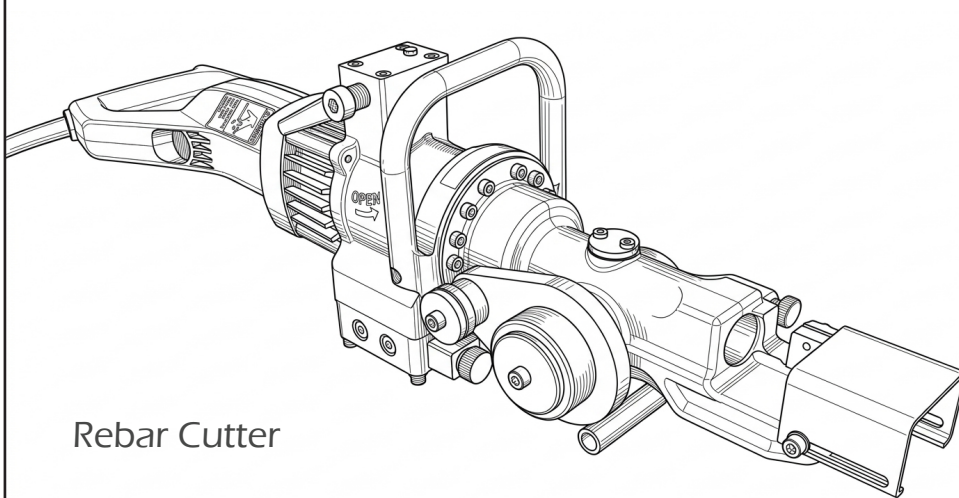

Rebar Cutter

This portable combination tool effectively cut and bends rebar (reinforcing steel) all in one tool with a single, powerful hydraulic tool.

The DBC-16H shears and bends up to #5 (16mm) Grade 60 rebar up to 180°.

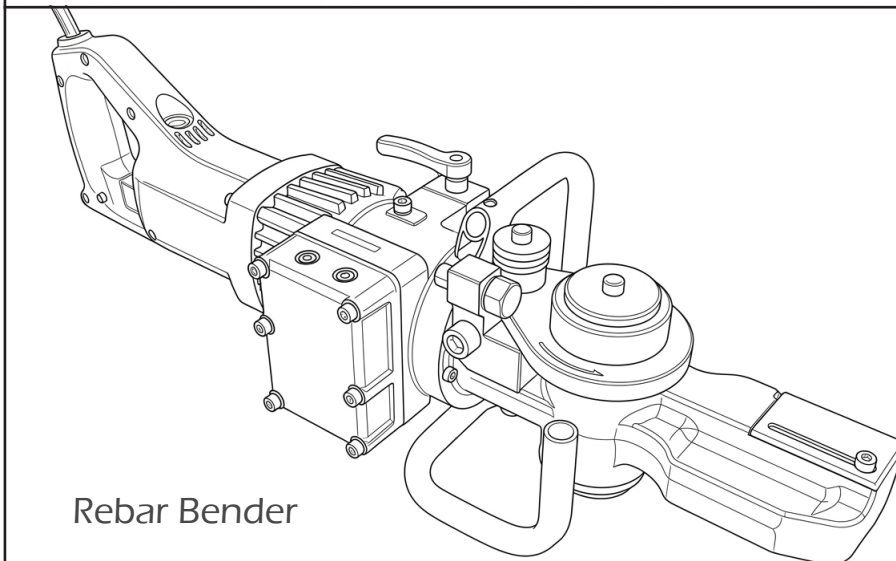

Rebar Bender

**Replacement
Cutting Blocks**

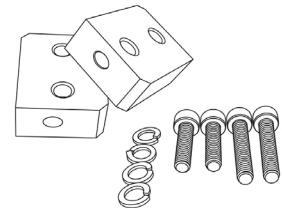

**Part Number
RB-16H**

Please note: This tool is rated for #5 (16mm) Grade 60 Rebar Only. Do not try to bend or cut material larger in size or rebar harder than grade 60 or you will cause tool damage or machine failure.

BN Products-USA™

3450 N. Sabin Brown Road | Wickenburg, AZ 85390

(800) 992-3833 | BNProducts.com

**OPERATOR
MANUAL**



IMPORTANT: READ THESE INSTRUCTIONS CAREFULLY BEFORE USING THIS TOOL

DBC-16H Cutter/Bender Specifications

Model No.	DBC-16H Cutting Mode	DBC-16H Bending Mode
Cut / Bend Speed	3 seconds	180 degree bend in 7 seconds
Center Roller	Not Applicable	2.42" (62 mm) Diameter (R 31)
Clearance (In-place)	1-3/4" (44.5 mm) from Surface	4.5" (115 mm) from Surface
Rebar Capacity	Grade 60 / Up to #5 (16mm)	Grade 60 / Up to #5 (16mm)
Power Supply	Electric motor 115v, 50/60 Hz – 10 amps, 1,050 Watt	
Total Weight (kg)	40 lbs. (18.2) Tool Weight , 62lbs. (28.2) Shipping Weight	
Tool Dimensions	25-1/8" L x 6-3/8" W x 8-5/8" H including lifting handles (cutter up)	
Carton Size	27-3/4" L x 10-1/2" W x 10-1/2" H or 3,060 cubic inches	

Operator Manual: Contents

TOOL SPECIFICATIONS	2	GUARD AGAINST ELECTRIC SHOCK	5
GENERAL SAFETY RULES	3	UNPLUG TOOL	5
WORK AREA SAFETY	3	INSPECTION	6
ELECTRICAL SAFETY	3	BLEEDING INSTRUCTIONS	6
PERSONAL SAFETY	3	GENERAL OPERATING INSTRUCTIONS	6
POWER TOOL USE AND CARE	3	PRE-USE CHECKS	6
SERVICE	3	WARM-UP	6
BASIC BENDING INSTRUCTIONS	4	STOPPER BOLT ADJUSTMENT	7
CUTTING REBAR	4	CUTTING	7
BASIC CUTTING INSTRUCTIONS	4	BENDING	7
BENDING REBAR	4	POINTS OF ATTENTION	7
BENDER ROLLER CHART	4	GENERAL MAINTENANCE	7
BENDING/ CUTTING	5	CUTTER BLOCK MAINTENANCE	7
REBAR IN-PLACE	5	CLEANING	7
SAFETY PRECAUTIONS AND OPERATING TIPS	5	OIL-LEVEL CHECK	7
GENERAL SAFETY	5	OIL-CHANGE	8
CUTTING SHORT PIECES	5	BOLT TIGHTNESS	8
DESIGNATED MATERIALS	5	CARBON BRUSHES	8
USE EYE PROTECTION	5	SCHEDULED MAINTENANCE	8
PROVIDE SAFETY BARRIERS	5		
EXERCISE PROPER CONTROL	5		

Ignorance of proper operating procedures can lead to accidents. If you have any questions about any proper use of this product, please contact the nearest authorized distributor/agent or call BN Products-USA™.



BN Products-USA™

A DIVISION OF BENNER-NAWMAN, INC.

DBC-16H

#5 REBAR BENDER / CUTTER OPERATOR MANUAL

GENERAL SAFETY RULES

WARNING: Read all instructions. Failure to follow all instructions listed below may result in electric shock, fire and/or serious injury. The term “power tool” in all of the warnings listed below refers to your main-operated (corded) power tool or battery-operated (cordless) power tool.

SAVE THESE INSTRUCTIONS

WORK AREA SAFETY

- Keep work area clean and well lit. Cluttered or dark areas invite accidents.
- Do not operate power tools in explosive atmospheres, such as in the presence of flammable liquids, gases or dust. Power tools create sparks which may ignite the dust or fumes.
- Keep children and bystanders away while operating a power tool. Distractions can cause you to lose control.

ELECTRICAL SAFETY

- Power tool plugs must match the outlet. Never modify the plug in any way. Do not use any adapter plugs with earthed (grounded) power tools. Unmodified plugs and matching outlets will reduce risk of electric shock.
- Avoid body contact with earthed or grounded surfaces such as pipes, radiators, ranges and refrigerators. There is an increased risk of electric shock if your body is earthed or grounded.
- Do not expose power tools to rain or wet conditions. Water entering a power tool will increase the risk of electric shock.
- Do not abuse the cord. Never use the cord for carrying, pulling or unplugging the power tool. Keep cord away from heat, oil sharp edges or moving parts. Damaged or entangled cords increase the risk of electric shock.
- When operating a power tool outdoors, use an extension cord suitable to outdoor use. Use a cord suitable for outdoor use reduces the risk of electric shock.

PERSONAL SAFETY

- Stay alert, watch what you are doing and use common sense when operating a power tool. Do not use a power tool while you are tired or under the influence of drugs, alcohol or medication. A moment of inattention while operating power tools may result in serious personal injury.
- Use safety equipment. Always wear eye protection. Safety equipment such as dust mask, non-skid safety shoes, hard hat, or hearing protection used for appropriate conditions will reduce personal injuries.
- Avoid accidental starting. Ensure the switch is in the off-position before plugging in. Carrying power tools with your finger on the switch or plugging in power

tools that have the switch on invites accidents.

- Remove any adjusting key or wrench before turning the power tool on. A wrench or a key left attached to a rotating part of the power tool may result in personal injury.
- Do not overreach. Keep proper footing and balance at all times. This enables better control of the power tool in unexpected situations.
- Dress properly. Do not wear loose clothing or jewelry. Keep your hair, clothing and gloves away from moving parts. Loose clothes, jewelry or long hair can be caught in moving parts.
- If devices are provided for the connection of dust extraction and collection facilities, ensure these are connected and properly used. Use of these devices can reduce dust-related hazards.

POWER TOOL USE AND CARE

- Do not force the power tool. Use the correct power tool for your application. The correct power tool will do the job better and safer at the rate for which it was designed.
- Do not use the power tool if the switch does not turn it on and off. Any power tool that cannot be controlled with the switch is dangerous and must be repaired.
- Disconnect the plug from the power source and/or the battery pack from the power tool before making any adjustments, changing accessories, or storing power tools. Such preventative safety measures reduce the risk of starting the power tool accidentally.
- Store idle power tools out of the reach of children and do not allow persons unfamiliar with the power tools or these instructions to operate the power tool. Power tools are dangerous in the hands of untrained users.
- Maintain power tools. Check for misalignment or binding or moving parts, breakage of parts and any other condition that may affect the power tools operation. If damaged, have the power tool repaired before use. Many accidents are caused by poorly maintained power tools.
- Keep cutting tools sharp and clean. Properly maintained cutting tools with sharp cutting edges are less likely to bind and are easier to control.
- Use the power tool, accessories and tool bits etc., in accordance with these instructions and in the manner intended for the particular type of power tool, taking into account the working conditions and the work to be performed. Use of the power tool for operations different from those intended could result in a hazardous situation.

SERVICE

- Have your power tool serviced by a qualified repair person using only identical replacement parts. This will ensure that the safety of the power tool is maintained. For service questions and information please call (800) 992-3833 or (928) 684-2813.

BASIC BENDING INSTRUCTIONS

Important: Always read, understand and obey the safety instructions included with your new DBC-16H #5 Combination Rebar Cutter and Bender before operating this tool or any other power tool.

CUTTING REBAR



(maximum #5, 16 mm, 5/8" grade 60 capacity):

~Step #1~

Place the rebar between the cutting blocks where you want to make your cut, make sure you always adjust the stopper bolt to keep the rebar at a right angle to the cutting blocks.

~Step #2~

Make sure the unit is plugged into the proper outlet 115V 50/60 Hz, pull the trigger switch which advances the piston forward to cut the rebar. Be careful to watch when cutting small pieces of rebar, always wear safety glasses and proper clothing during use.

~Step #3~

The release valve retracts the piston at anytime during the cutting or bending operation. (Do not push the trigger switch and release valve at the same time.) When doing repeated cuts, only retract the piston as far back as needed to place another piece of rebar between the cutting blocks. This will save you time because the piston does not have to fully retract in order to do repeated cuts.

NOTE: CAUTION

The bending roller rotates 180 degrees during the cutting operation. Do not try to bend and cut rebar at the same time.

BASIC CUTTING INSTRUCTIONS

Important: Always read, understand and obey the safety instructions included with your new DBC-16H #5 Combination Rebar Cutter and Bender before operating this tool or any other power tool.

BENDING REBAR



(maximum #5, 16 mm, 5/8" grade 60 capacity):

~Step #1~

Place the rebar between the bending rollers (small moving roller and larger fixed bending roller) where you want to make your bend, make sure you always adjust the stopper bolt to keep the rebar at a right angle to bending rollers.

~Step #2~

Make sure the cutting cover is closed while bending the rebar. (Do not attempt to bend and cut rebar at the same time.)

~Step #3~

Markings on the center roller indicate approximate bending angles. When the marking is pointing towards the user the angle of the bend will be approximately the angle indicated on the center roller.

~Step #4~

After bend is complete, push the release valve in the direction of the arrow in order to bring the rollers back to the start position. (Do not push trigger at the same time as using the release valve.)

BENDER ROLLER CHART

Rebar Diameter Size	Fixed Center Roller	Fixed Moving Roller	# of Grade 60 Rebar Bent
# 3 (3/8") (10mm)	2.44" (62 mm)	1.30" (33 mm)	2 pieces at one time
# 4 (1/2") (13 mm)	2.44" (62 mm)	1.30" (33 mm)	1 piece at one time
# 5 (5/8") (16 mm)	2.44" (62 mm)	1.30" (33 mm)	1 piece at one time

Notes: Be cautious on projects that strictly require meeting CRSI bending specifications. BN Products offers other rebar benders that can meet current CRSI specifications.

Current CRSI specifications are for standard bends up to 180 degrees, they should be bent around a center roller 6 times (6D) the diameter of the rebar. And for stirrup hooks or seismic stirrup hook or ties should be bent around a roller 4 times (4D) the diameter of the rebar. More information can be found on their website: www.crsi.org

**BENDING/ CUTTING
REBAR IN-PLACE**

The DBC-16H can be used for bending rebar in-place, protruding from a wall, floor or column. The closest bend to the surface would be a minimum of 4.5" or 115 mm, see drawing below. Please make sure there is adequate space for the bending and cutting unit to complete the bend.

**SAFETY PRECAUTIONS
AND OPERATING TIPS**

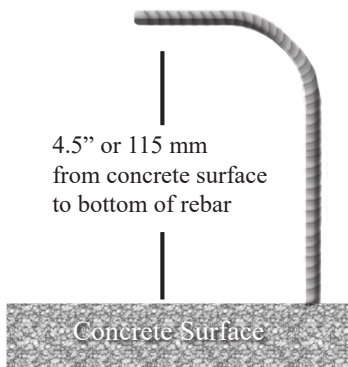

It is extremely important to adjust the stopper bolts to keep the rebar parallel to with the bending rollers or at a right angle to the cutting blocks. Replace damaged stopper bolts.

When positioning the rebar between the rollers, make sure that the rebar lies flat on the unit's surface. If the rebar is not flat on the surface, the action of the rollers may cause the rebar to fly out or may cause damage to the stopper bolt.

Do not try to bend or cut materials harder than grade 60 rebar as they will either cause the cutting blocks to crack or bring about machine failure. Benner-Nawman offers other rebar cutters with special cutting blocks for grade 75 rebar.

Place this unit on plywood or an elevated surface when operating. Do not operate this unit directly on a dirty, dusty or sandy surface. This will allow the cooling fan on the armature to intake dirt, sand and or dust into the electrical system causing premature wear and ultimately machine failure. Keep your unit clean; remove rebar debris with a soft brush after operating machine.

GENERAL SAFETY

Use rebar cutters on maximum Grade 60 steel reinforcing bars only. These tools are not to be used in cutting other kinds of metal or materials. Do not cut ungraded rebar.

CUTTING SHORT PIECES

There is always a chance that the cut end may shoot out, especially if less than 30cm (1 foot) in length.

DESIGNATED MATERIALS

Exceeding designated material specifications greatly increases this risk and will also damage the tool. Do not attempt to cut rebars harder, thicker or thinner than those specified).

USE EYE PROTECTION

Wear safety goggles, safety glasses with side shields or a face shield when using cutter.

PROVIDE SAFETY BARRIERS

Erect safety screens to protect coworkers from possible flying ends. Place a safety screen under the rebar when working in high places.

EXERCISE PROPER CONTROL

Hold cutter firmly and maintain proper footing and balance. Do not overreach. When working in a high place, secure cutter to scaffolding with a safety rope. Check that power cord is not fouled and keep cord away from sharp edges and heat. Check that all adjusting wrenches have been removed before using cutter.

GUARD AGAINST ELECTRIC SHOCK

To avoid possible shock, do not handle cutter with wet hands or use cutter in the rain or damp places. Be aware of all power lines, electric circuits and other hazards that may be contacted, especially those that are below the surface or otherwise hidden from view. Never attempt to pick the tool up by use of the electric cord.

UNPLUG TOOL

Disconnect cutter from outlet when not in use and before cleaning, adjusting or servicing. Do not disconnect plug from outlet by pulling the cord. Always check that the switch lock is OFF before plugging in.

INSPECTION

Inspect cutter before each application. Faulty or loose cutter blocks could result in personal injury. Keep handle dry, clean and free from oil and/or grease. Keep housing and piston free of dirt and iron filings. Check that no screws or bolts are loose or missing. Follow instructions for maintenance. Inspect switch, cord, plug and any extension cable at regular intervals. It is a good idea to inspect the housing for any cracks before operating.

DO NOT EXCEED MAXIMUM CUTTING PRESSURE BY ADDING TO OR MODIFYING THE HYDRAULIC PUMP.

BLEEDING INSTRUCTIONS

You may have to bleed the hydraulics on your cutter if the tool runs unusually slow or doesn't have the pressure to cut normally. Do not run tool with low or no oil. For best results please follow these directions:

1. If piston is still moving, run the tool for 2 minutes to warm the oil inside. If the piston is not moving, add oil before warming up for 2 minutes.
2. When the oil is warm, run the piston out to full extension
3. Remove the oil plug and top it off with oil.
4. Make a seal with your thumb over the oil plug opening.
5. Push the release valve to return piston.
6. When the piston is completely retracted in the open position, gently roll your thumb to let the unwanted air escape.
7. Repeat step #5 and #6 at least three times.
8. Add oil only when the piston is fully extended.
9. If you have to add additional oil, repeat #5 and #6.
10. Replace the oil plug and tighten it.
11. The operation is now complete.

We recommend the following 20-wieght Non-Detergent Hydraulic Oils for use with our tools (anti-foam anti-abrasion): Tellus 68 (Shell), Rando HD 68 (Texaco) or Chevron AW 68 (Chevron). Hydraulic oil can also be ordered in quart containers from your Diamond Tool Distributor.

GENERAL OPERATING INSTRUCTIONS

CAUTION: Indicates hazard that could result in minor personal injury and/or product damage.

CARE: Indicates hazard that will result in product damage.

PRE-USE CHECKS

1. Check oil level. (See Maintenance)
2. Check condition of cutter blocks and tightness of cutter block bolts. (See Maintenance) - **CHECK FOR CRACKS IN HOUSING**
CAUTION: Using loose or cracked cutter blocks may result in injury to operator as well as damage to the tool.
3. Check that the power source is appropriate to the cutter.
CARE: If voltage is too high, the motor will burn out. If voltage is too low, insufficient power will be generated. Never use DC current.
4. Check that power supply is properly grounded.
CAUTION: Failure to ground power supply may result in electric shock to operator (DC-16LZ, DC-16W, DBD-16H and DC-32WH have double-insulated motors and do not require grounding.)
5. Check that cord is undamaged and that plug is not loose.
CAUTION: Cut or abraded covering could result in a short and Electric shock to operator.
6. If an extensions cable is to be used, make sure that it is undamaged and that it is the proper wire gauge thickness for the length. See table below.

Length	110/115 50/60 Hz Cable Size (AWG)
Up to 15mm (50 ft.)	14
Up to 30mm (100 ft.)	12
Up to 45mm (150 ft.)	10

WARM-UP

In cold weather you should warm up the tool unit for 30-60 seconds so that the hydraulic oil reaches the proper viscosity. Pull trigger-switch to extend piston and release when it has reached its full stroke. Repeat 15-20 times.

STOPPER BOLT ADJUSTMENT

THE STOPPER BOLT IS A CRITICAL COMPONENT OF THIS PORTABLE CUTTER...

CUTTING

The adjustable stopper functions to maintain the rebar in the correct position during cutting and must be properly set for each size of rebar before use.

1. Screw in stopper to provide sufficient clearance for rebar.
2. Insert rebar fully into U-shaped support. Make sure that rebar is resting on the base of the support.
3. Keeping rebar at right angles (90 degrees) to front cutter block, screw out stopper until it is just touching the rebar. Once set, the stopper needs no further adjustment while cutting rebar of the same diameter, but must be reset for a different size rebar.

CAUTION: Failure to correctly set the stopper bolt will result in excessive wear of cutter blocks and may cause cut end to fly out. This will also lead to piston and cylinder damage.

BENDING

1. Screw in stopper bolt to provide sufficient clearance for rebar.
2. Place rebar between the bending rollers (small moving roller and the larger fixed roller.)
3. Adjust the stopper bolt to keep the rebar at a right angle (90 degrees) to bending rollers.

POINTS OF ATTENTION

1. Be especially careful when cutting off short lengths (30cm/12" or less) as the cut end tends to fly out.

CAUTION: Flying ends are a hazard to all personnel in the vicinity. Erect safety screens.

2. Do not cover air vents or operate the tool on dirt – use a plywood base under the rebar cutter to keep armature and fan clean

CARE: If the vents are covered, the motor will overheat and may burn out.

3. If hydraulic oil exceeds 70 degrees C (158 degrees F) in temperature, power will drop. Allow unit to cool before resuming operation. (Be particularly careful in summer, when the aluminum pump case heats up more quickly.)

4. If a drop in power is observed and motor is unusually hot, check carbon-brushes. (See maintenance)

5. If piston should ever fail to retract completely, push rear cutter block backwards to manually retract piston or check under piston to remove and debris keeping the piston from retracting.

CAUTION: Use a rebar or flat metal bar for this purpose. Never push cutter block with any part of the hand, even if gloved.

GENERAL MAINTENANCE

CUTTER BLOCK MAINTENANCE

Before using, always check that the two bolts on each cutter block are properly tightened. Using a loose block will result in damage to block and housing. Also check condition of cutter blocks. If either cutting edge is dull or chipped, remove retaining bolts and rotate both blocks so that two new edges come into use. Replace and tighten bolts. (Each block has four cutting edges.) When all four cutting edges have been used or if either block is cracked or otherwise damaged, replace both blocks.

CAUTION: A loose or cracked block may result in injury to operator.

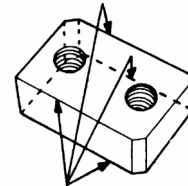

CLEANING

Clean your tool every day, preferably immediately after use.

CAUTION: Wear gloves to protect hands from metal splinters.

Do not use an air gun: blasting with air can cause metal filings and/or dust to get into eyes and respiratory system.

Disconnect the unit. Wipe or brush away all dirt and metal filings. Pay particular attention to the lower half of the piston, where dirt is more easily accumulated.

NEVER USE YOUR CUTTER TO CUT REBAR IN WET CONCRETE.

OIL-LEVEL CHECK

As the cutters are hydraulically operated, the oil-level must be checked at frequent intervals, preferably every day. Failure to maintain the oil at the proper level results in a drop in pressure and loss of cutting power.

CAUTION: Hydraulic oil is highly flammable. Keep away from sparks and naked flame.
Do not smoke.

CAUTION: Hydraulic oil may cause inflammation of the eyes and skin. If ingested, it will cause diarrhea and vomiting. In case of eye contact, rinse in clean water for at least 15 minutes and consult a physician. In case of skin contact, wash thoroughly with soap and water. In case of ingestion, consult a physician immediately. Do not induce vomiting.

1. Oil should be warm but not hot. Warm up unit if cold.
2. Adjust stopper and make three or four cuts, noting exactly at what point the rebar is actually breaking.
3. Pinch a short piece of rebar, stopping just before it breaks off. Unplug unit from power source.
4. With partially severed rebar in place, oil-plug should be straight up. (If unit is hot, allow cooling down.)
5. Remove oil-plug and seal-washer (packing).

CAUTION: Never remove oil-plug when unit is hot or oil will spurt out.

6. Check that oil is level with bottom of plug hole (i.e. that pump case if full to the brim).

If oil level is too low, top up with 20-weight hydraulic oil with anti-foam and anti-abrasion properties (ISO viscosity grade VG46, e.g. Shell oil Tellus 68, Mobil oil DTE-25 or Esso Uni power SQ46).

7. After topping off, extract air from system. Gently tilt cutter lengthwise and return it to a level position. Top off again and tilt in the opposite direction. Repeat this process until all air has been extracted.

CARE: Cutter cannot function properly if oil contains air bubbles.

8. Replace seal washer (packing) and oil plug. Connect cutter to power source and completely sever rebar.

OIL-CHANGE

The hydraulic oil should be changed at least once a year, sooner if it appears dirty.

NOTE: Hydraulic oil should be warm before draining

1. Unplug unit from power source. Remove oil-plug and packing. Turn cutter over and drain oil into a suitable receptacle. When oil ceases to drain out, tilt unit to rear so that oil trapped in the piston housing can run out. When housing is empty, tilt unit in the opposite direction to empty the residue in the pump case.

2. With drain-hole uppermost, slowly fill the unit with fresh oil. Replace plug and lightly tighten. Connect unit to power source and advance piston two or three times. Unplug unit and remove oil-plug. Top off oil-level and replace plug.

3. Finally, follow procedure for oil-level check. (Steps 2-8).

NOTE: Dispose of hydraulic oil in accordance with local regulations. Do not pour into the sea, a river, a lake or drains.

BOLT TIGHTNESS

Once a week, or after every 500 cuts, check the tightness of all bolts; especially those bolts securing the housing to the cylinder. Loose bolts will result in a loss of power. Make sure that the bolts holding both cutter blocks are also tight

CARBON BRUSHES

Inspect the two carbon brushes at least once every two months. (Nominal brush life is 200 hours).

CARE: Worn brushes will result in power loss, cause the motor to run hot and irreparably damage the armature.

1. Disconnect unit.
2. Unscrew both brush caps and pull out carbon brushes.
3. Replace brushes if less than 6mm or 1/4" in length.

SCHEDULED MAINTENANCE

Return the unit to an authorized agent for tool maintenance at least once every two years, sooner if subjected to heavy use. Call (800) 992-3833 to inquire about scheduling Service from BN Products-USA™.

