

**#8 (25mm) Electric-Hydraulic
Rebar Shear**

**Product
Parts Guide**

DIAMOND®

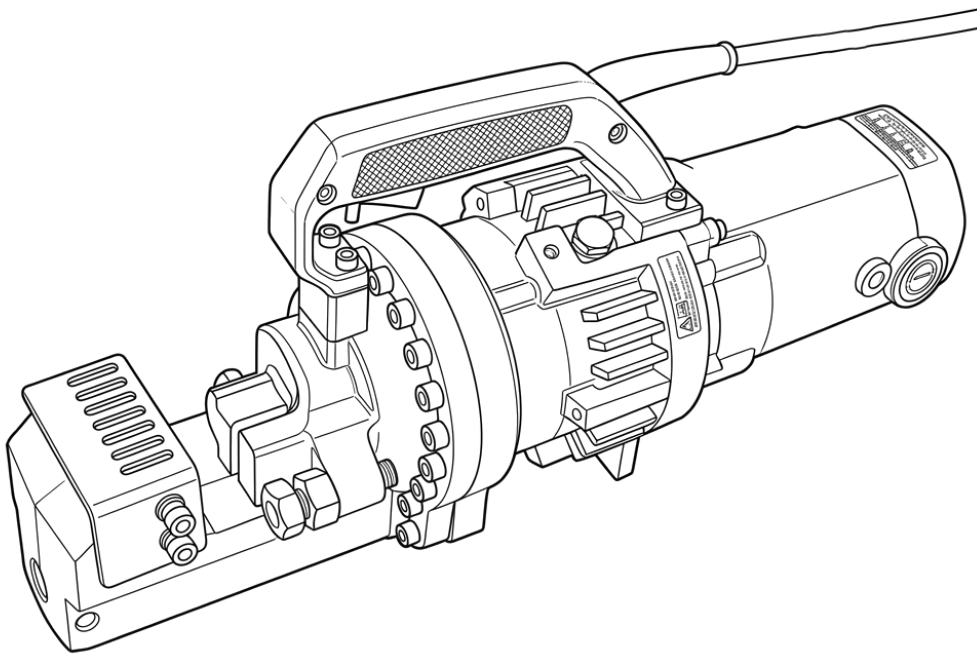

DC-25X
Electric/Hydraulic
Rebar Cutter

The DC-25X portable heavy-duty rebar cutter will safely, efficiently, and cleanly cut rebar up to #8 (1") diameter grade 60.

It's the fastest, safest, and most economical way to cut rebar on the job. A safety relief valve for retracting the piston and a cutting guard are standard features.

Replacement Cutting Blocks:

- RB-25X - Standard Pair
- RB-25X/75 - For Grade 75 Rebar

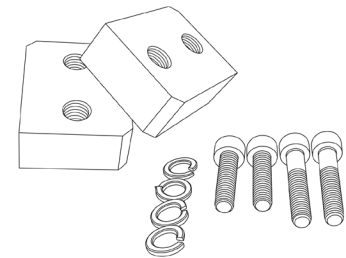

Revision 4 - May 2026

DC-25X REBAR CUTTER | SERIAL NUMBER

S/N #

PRODUCT PARTS GUIDE

This manual lists service and replacement parts for the product model listed in this document. Information in this publication represents data available at the time of print. BN Products-USA™, a division of Benner-Nawman, Inc., reserves the right to change this publication, and the products represented, without notice and without any obligation or liability, real or implied.



BN Products-USA™
3450 N Sabin Brown Road
Wickenburg, AZ 85390

(800) 992-3833
BNProducts.com

DC-25X Parts View

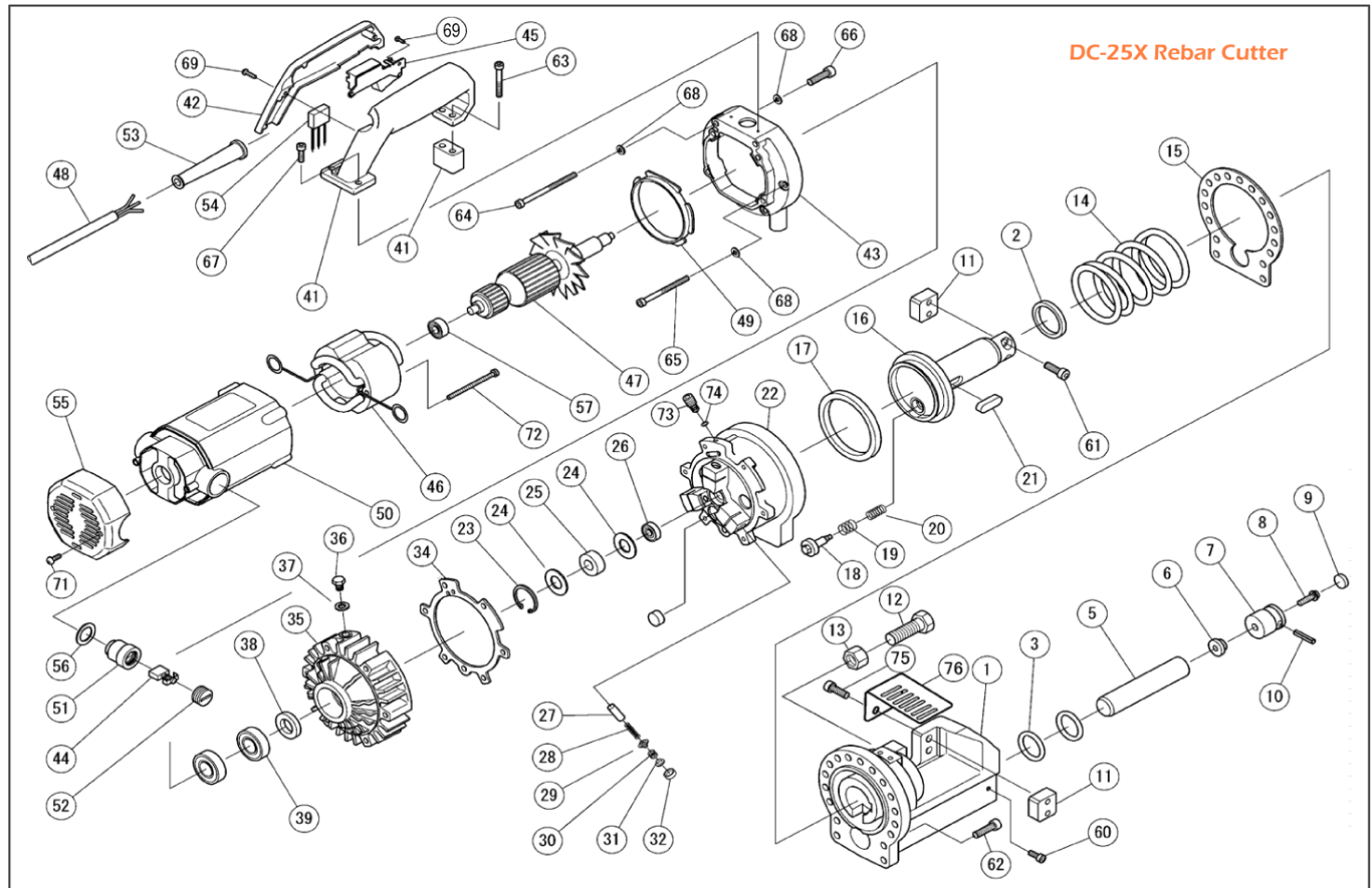

#	Part Number	Description	Qty	#	Part Number	Description	Qty
1	1C2601	HOUSING	1	13	7N016T11	STOPPER NUT M16	1
2	1C2602	SEAL PACKING SKY40	1	14	1C2607	RETURN SPRING	1
3	7ORP32	O RING P32	2	15	1C26141	CYLINDER PACKING	1
4	This line intentionally blank			16	1C2604	PISTON	1
5	1C2570	AIR BAG	1	17	1C2518	SEAL PACKING	1
6	1CM2027	AIR BAG NUT	1	18	1C2519	RETURN VALVE	1
7	1C2620B	HOUSING CAP	1	19	1C2521	RETURN VALVE SPRING	1
8	1CM2028	AIR BAG SET BOLT	1	20	1C25221	VALVE END SPRING	1
9	1C1505	AIR FILTER	1	21	7K1208035R2H	PISTON KEY	1
10	7SP06030W	SPRING PIN D6X30	1	22	1C1024200	CYLINDER	1
11	1C1911	CUTTER BLOCK NO.3	2	23	7SRH035	SNAP RING H35	1
12	7B16050T11	STOPPER BOLT M16X50	1	24	1C2525	BEARING GUIDE	2

DC-25X Parts Listing

#	Part Number	Description	Qty	#	Part Number	Description	Qty
25	7RNAS10	NEEDLE BEARING	1	51	7HTK957001B	BRUSH HOLDER	2
26	7609	BALL BEARING 609	1	52	7HTK940540B	Crush Cap	1
27	1C2610	RAM	3	53	7HTK940778B	Cord Armor	1
28	1C1330	RAM RETURN SPRING	3	54	7HTK930039B	Condenser	1
29	1C13281	DELIVERY VALVE	3	55	7HTK957980B	Motor cover	1
30	1C1331	DELIVERY VALVE SPRING	3	56	7HTK956683B	Temperature Sensor	2
31	1C13352	SPRING GUIDE	3	57	762002RU	BALL BEARING 6200VV 1C2612J	1
32	1C13292	PUMP HEAD SEAL	3	58	This line intentionally blank		
33	3P1044	MAGNET FILTER	3	59	This line intentionally blank		
34	1C4194200	PUMP CASE PACKING	1	60	7CB06016	CAP BOLT M6×16	2
35	1C25391	PUMP CASE	1	61	7CW08025	CAP BOLT W/WASHER M8X25	2
36	7B10015	OIL PLUG M10X15	1	62	7CB08030	CAP BOLT M8×30	17
37	7WF10	SEAL WASHER WF10	1	63	7CB06045	CAP BOLT M6×45	2
38	1C2542	OIL SEAL SC20-35-8	1	64	7CB06090	CAP BOLT M6×90	2
39	76004VV	BALL BEARING 6004VV	2	65	7CB06075	CAP BOLT M6×75	4
40	1C2616	HANDLE PIECE	1	66	7CB06035	CAP BOLT M6×35	4
41	1C2618	MAIN HANDLE	1	67	7CB06018	CAP BOLT M6×18	2
42	1C1946	SWITCH COVER	1	68	7SW006	SPRING WASHER M6	10
43	1C2611	CASE COVER	1	69	7P204016	PAN HEAD BOLT M4X16	2
44	7HTK999044B	CARBON BRUSH SET	1	70	This line intentionally blank		
45	7HTK971390B	SWITCH	1	71	7PB05012	PANHEAD BOLT, Washer M5×12	2
46	7HTK957972HB	STATOR COIL	1	72	7PB05065	PAN HEAD BOLT M5×65	2
47	77HTK360716CB	ARMATURE ASS'Y	1	73	1C4160601	RELEASE VALVE	1
48	1C1961F	CORD SET	1	74	7ORS4	O RING	1
49	7HTK957973B	FAN COVER	1	75	7CW08030	CAP BOLT W/WASHER M8X30	2
50	7HTK957970B	MOTOR HOUSING	1	76	1C4199800	CUTTER GUARD	1

Product & Customer Service Information

DC-25X #8 Heavy-Duty Rebar Cutter

Maximum shearing Diameter	#8 or 1" (25 mm) Grade 60 Rebar
Cutting Speed	5 seconds - 1" diameter Grade 60
Cutting Pressure	30 tons (maximum)
Power Supply	115V AC / 60 Hz / 12A
Tool Weight	49.6 lbs. (22.5 kg)
Dimensions L x W x H (mm)	20" (515) x 5.9" (150) x 9.8" (250)

BN Products-USA™

Customer Service

Toll-Free (800) 992-3833 mail@bnproducts.com

www.BNProducts.com

Replacement parts can be purchased from BN Products-USA™ by calling our customer service at 1-800-992-3833, M-F 8:00am-4:30pm MST. Parts and accessories that wear down over the course of normal use are **not** covered by the limited manufacturer warranty.

Product Part Numbers

Part Numbers contained within this Guide are unique to BN Products-USA™ and Diamond Tool/IKK Co., LTD. Such part numbers are not universal identifiers that can to be directly referenced by non-OEM, third-party, or after-market parts suppliers.



BN Products-USA™

(800) 992-3833

BNProducts.com

*Quality
Since
1925*
