

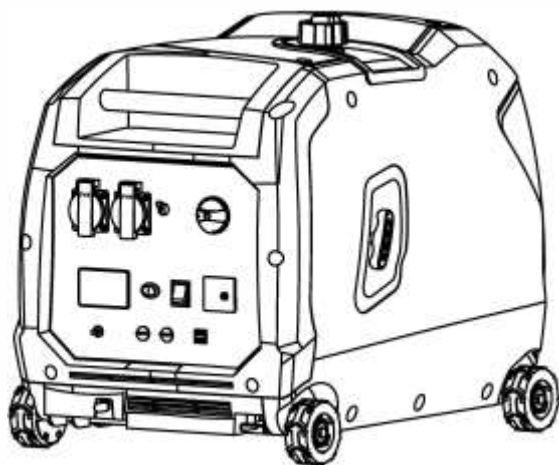

**BN PRODUCTS-USA, LLC.**

# **INVERTER GENERATOR OPERATIONAL MANUAL BNG3300i**



*Tips-Please read this operational manual before use,be sure to use generator set under the circumstance of safety & environmental friendly.*



*Please safekeep this operational manual along with inverter generator set in case we need to consult in emergency. The operational manual is a permanent part of generator set, if you'll lend out or resell the machine to others, please attach this operational manual with.*

*The technical specifications of relative information in this operational manual will take effect when it is approved to print, the content of this operational manual is based on the machine which is being produced. reserves the right to change everything in this operational manual without notice.*

# Content

1 Preface .....	01
2 Security regulation .....	02
3 Control function .....	08
4 Check before use .....	16
5 Operate .....	18
6 Application scope .....	24
7 Maintenance .....	25
8 Keeping custody ... ..	31
9 Failure remove .....	32
10 Technical parameter .....	33
11 Electricity principle diagram .....	34

# Preface

Thanks for choosing generator set produced by .

This inverter generator is a compact,well-performance,air-cooled & engine driven home use generator set,which is suitable for no municipal grid area & abrupt electrical power cutting-off.

We suggest operators to read this operational manual before use,and completely understand all requirements & operational steps for the machine.If there is anything in the operational manual like start,operation & maintenance procedures you are unclear,please contact with your nearest distributor, technicians will instruct you how to use this equipment properly & safely.Meanwhile,we suggest you to consult with distributors about how to start this machine and its operational steps.

Only the machine be properly reserved ,operated & maintained. The generator set could work safely,effectively & reliably.Before to operate & maintain the generator set,be sure to:

- Please be familiar & strictly obey local laws
- Please carefully read & obey all safety warnings in this operational manual.
- Please let your family to be known of all safety warnings in the operational manual.

Of course, we can not foresee all emergency possibilities .Therefore ,warnings in this operational manual & tags on the machine are not possible to include all.If we don't advise special suggestions for working methods or operationa skill s,please operate under the condition of personal safety.Besides,make sure that it won't damage the generator set with these operational procedures, working methods & operational skills.

In order to use the machine safety,please carefully read stickers with extremely important safety warning sign & both in manual & on the machine.

It may cause enormous injury if not follow as instruction.

It may cause serious injury if not follow as instruction.

It may cause injury if not follow as instruction.

**NOTICE** | If not follow as instruction.Not only your generator set may get damage,but also your other properties.

## Security rules



i

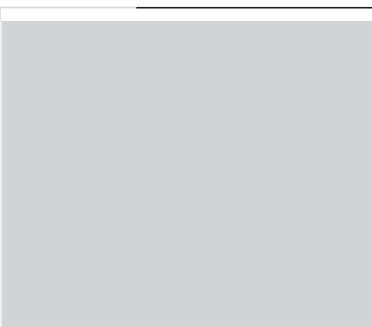

**⚠ WARN**

*Please keep the machine clean.  
Don't sprinkle gasoline or  
inflammable on the machine.*



**⚠ WARN**

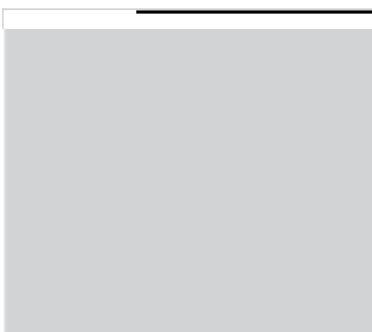



!

*Be sure the machine stopped when refuel for the machine.*



*Don't refuel when you are smoking or near flames .*

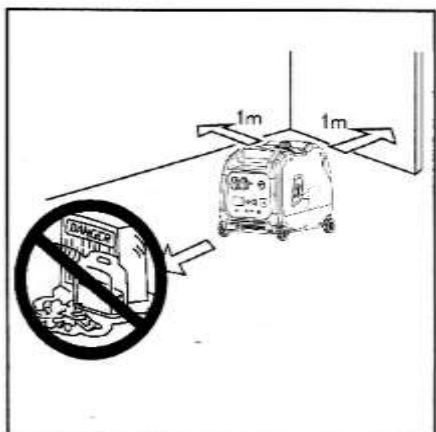

**⚠ WARN**

- *Please place the machine out of reach by children or strangers*
- *Don't put anything inflammable around the machine when it is running .*
- *Please keep the space clear in 1 meter around the machine. Otherwise ,it may cause the machine high temperature .*

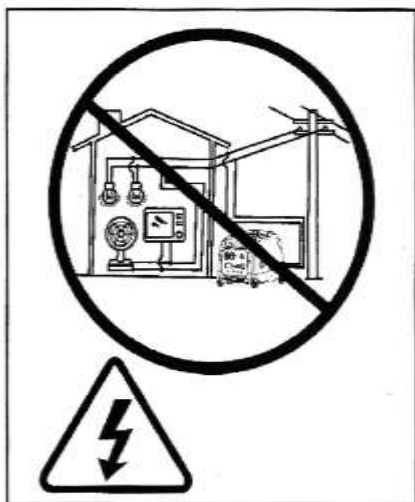

!

*Don't connect the machine with the municipal power supply & other generators, please use it solely.*

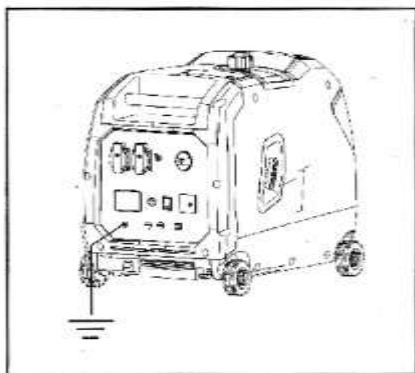

**⚠** WARN

*Must be connected with earth.*

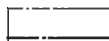

Please be sure the earth wire has enough big electric flux.

*Diameter of earth wire  
0.12mm/A  
eg: 10A-1.2mm*

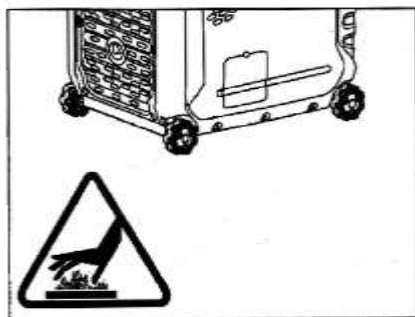

**⚠** WARN

*The exhaust port of generator set is quite hot, please be careful not to get to scald.*



## Connect with home power

That the generator set be connected with home power supply as standby power ought to be connected by professional electricians .

Please carefully check whether the connection of electrical appliances are reliable after the generator set is with the load,imp roper connection of electrical appliance may cause the generator set damage,burning or even disasters.

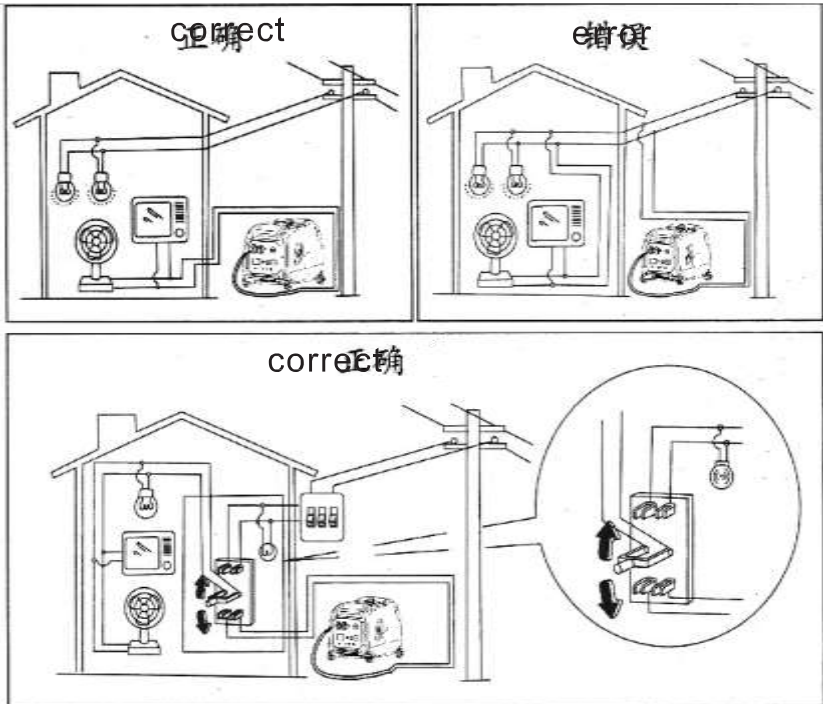

## Others

Please keep intake port ,exhaust port & ventilation hole under the bottom of generator set away from debris & water.If those ventilation holes are blocked,it may cause damage to generator ,inverter or altern ator .

Don 't put the generator set together with other things when move ,store or use the generator set,If the fuel leak,it may cause damage for generator set or your properties.

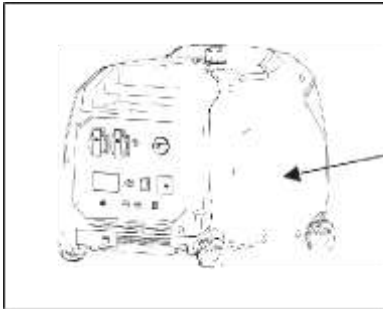
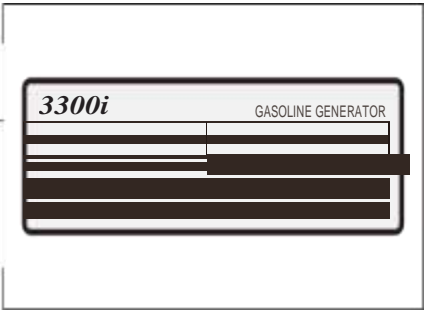
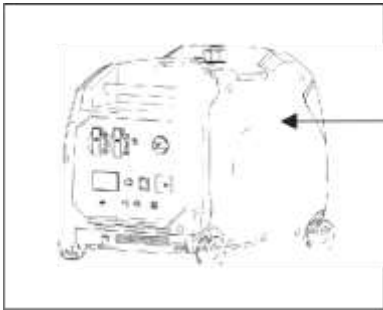

Owner 's Manual

Please read owner's manual carefully before operation.



Safety Warning

Users will get hurt without following the instructions .



Electric Shock

It shows the charged body. Be careful.







Caution Hot

High temperature during operation may cause serious burns.



Caution Water

Do not expose the plug or the equipment with electricity to rain or moisture.

	<b>Danger</b>	Do not operate the generator in a closed area.
	<b>Fire Hazard</b>	Do not smoke around the generator.
	<b>Noise</b>	Do not stand close to the generator for a long time, it may affect your listening.
	<b>Ground Terminal</b>	Please connect the generator to the ground before use.

# Appearance

- (1) fuel tank gap
- (2) handle
- (3) control panel parts
- (4) battery
- (5) inverter
- (6) recoil starter grip
- (?) louver
- (B) muff/er
- (9) oil gauge
- (10) oil dipstick
- (11) air cleaner
- (12) carburetor
- (13) spark plug
- (15) oil dip stick cover

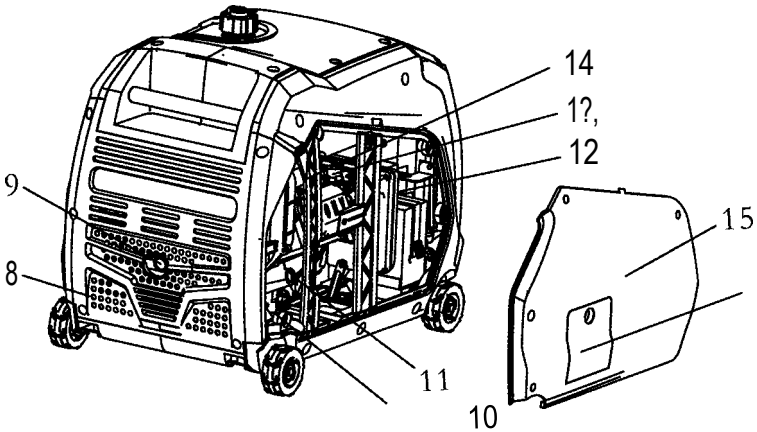
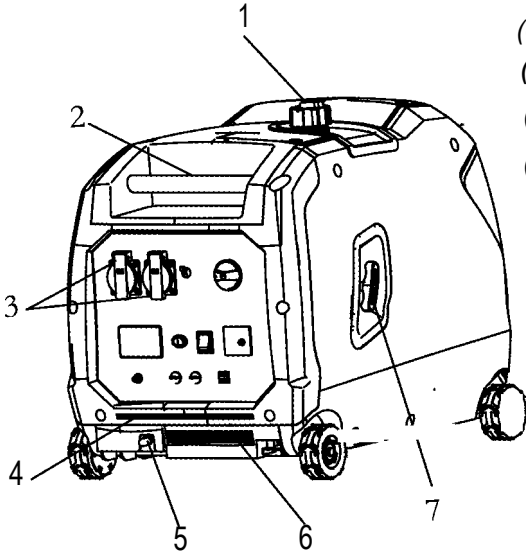

# AC 100V

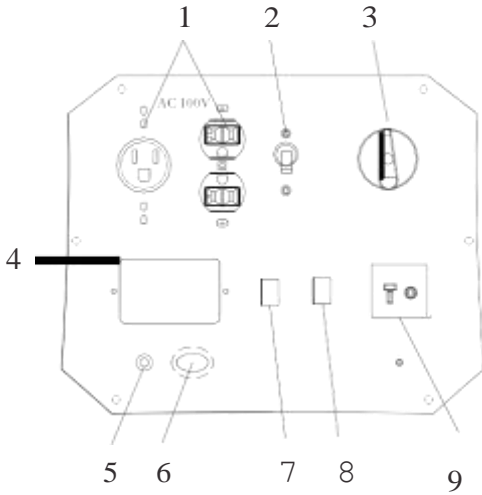

- (1) AC receptacle
- (2) Circuit breaker
- (3) Combination switch three-in-one
- (4) Multifunctional meter
- (5) Ground terminal
- (6) Idle switch
- (?) Electric switch
- (BJ) Frequency diverter switch
- (9) OC receptacle with

# AC 120V

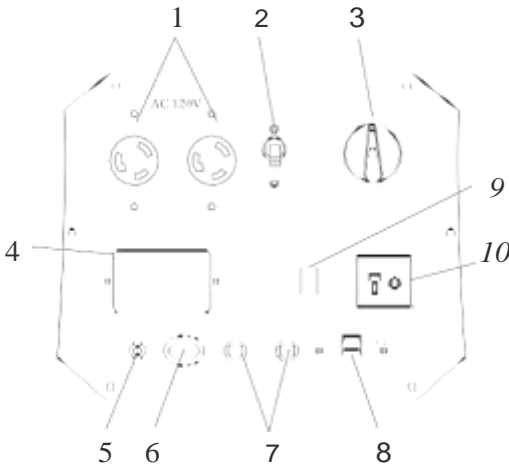

- (1) AC receptacle
- (2) Circuit breaker
- (3) Combination switch three-in-one
- (4) Multifunctional meter
- (5) Ground terminal
- (6) Idle switch
- (?) Receptacle in parallel
- (B) USBport
- (9) Electric switch
- (10) DC receptacle with

# AC 230V

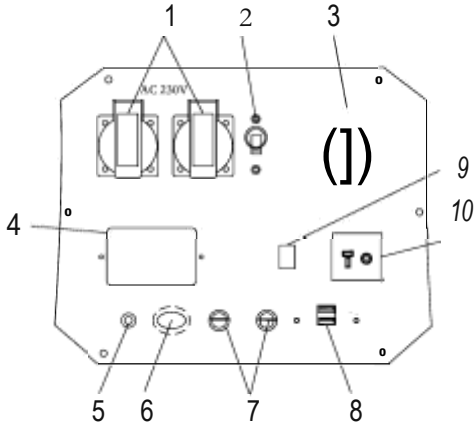

- (1) AC receptacle
- (2) Circuit breaker
- (3) Combination switch three-in-one
- (4) Multifunctional meter
- (5) Ground terminal
- (6) Idle switch
- (7) Receptacle in parallel (B) USBport
- (9) Electric switch
- (10) DC receptacle with

## Control function

combination switch three-in-one ( hereinafter referred to as "combination switch")

1. When the engine and fuel switch is on the OFF position, the ignition circuit is in a closed state; the fuel switch in the OFF position, the engine can not operate.
2. When the engine, fuel, choke rod switch is in the ON position, the ignition circuit is in a working state; the fuel and choke rod switch is open, the engine can work normally.
3. When the engine, fuel, choke rod switch is in the CHOKE position, the ignition circuit is in a working state; the fuel switch is open and choke rod is closed, the engine can start normally.

**NOTICE:** When the engine is in a warm state, there is no need to close the choke rod switch( no need to put switch on the @ position ) .

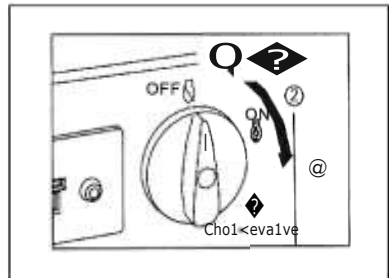

# Control function

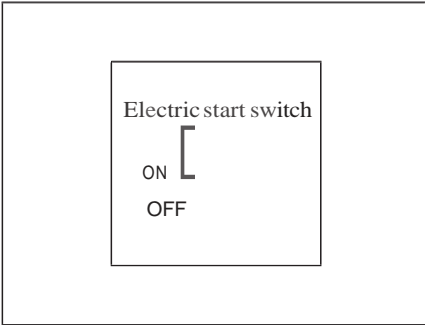

**CD** When it is in the "ON" position, the engine starts to work.  
Ⓡ When it is in the "OFF" position, the engine stops running.

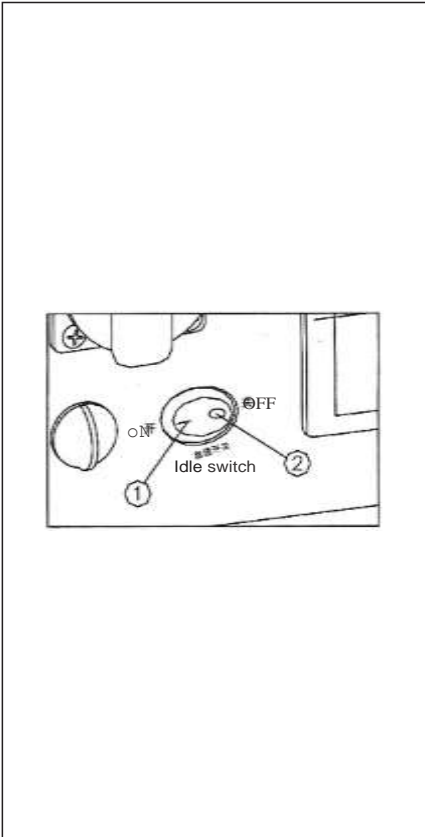

## Economical Switch

**CD "ON"**  
When the economical switch is in the 'ON' position, the energy-saving equipment will control the rotating speed of the engine according the loading of the generator. In this case, the generator could get economical consumption of fuel and lower noise.  
Ⓡ "OFF"  
When the economical switch is in the "OFF" position, the engine works at the speed of 3600 r/min whether it is connected with other equipment or not.

**NOTICE:** When the equipment with high starting current such as compressor, immersible pump, is used on the generator, the economical switch must be closed.

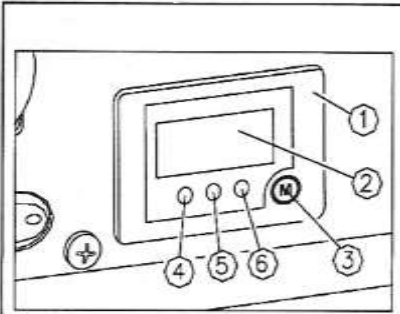

- (1) Multi-function table.
- (2) LCD.
- (3) operation Health.
- (4) Oil alarm indicator lamp.
- (5) Fault indicator liJJht.
- (6) AC indicator.

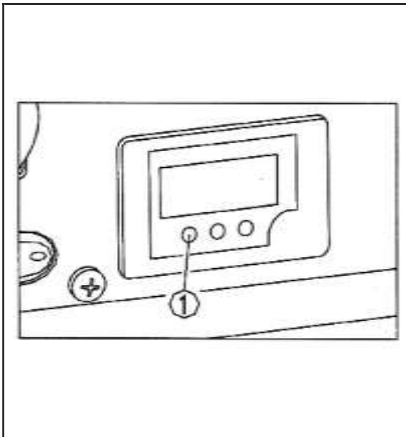
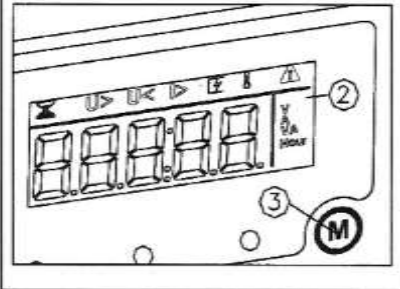

## LCD

During normal running :

The @ button shows the voltage, current, frequency, hours and a current time recurrently. Running under fault condition:

U>a. it says AC is over-voltage, the letter "AC" will show up.

(AC and number are showed recurrently) .

b. it says DC is over-voltage, the letter "DC" will show up.

(DC and number are showed recurrently) .

U<a. it says AC is under-voltage, the letter "AC" will show up.

(AC and number are showed recurrently) .

b. it says DC is under-voltage, the letter "DC" will show up.

(DC and number are showed recurrently) .

I> output is overcurrent.

( Generator is short circuit

Generator is too hot.

& It's time to have service.

The oil alarming system will automatically close the engine when the oil in the crankcase falls below the safety line, and the oil indicator will light up; The engine will start again when refueling engine to the oil level.

Notice : If the engine has stalled or cannot be started, please rotate the combination switch to the 'ON' position, then pull the recoil starter grip. If the oil indicator flickers for seconds, it shows the oil is not enough, and please refuel engine oil.



When the overload indicator lights up and the generator checks that the output of the connected electrical equipment has been overloaded resulting in overheating of the frequency converter or an increase in the AC voltage. At this point AC protector work stop the generator power generation to protect the generator and connected electrical equipment. The AC indicator(green) goes off, the overload indicator(red)lights, but the engine does not stop running.

When the overload indicator light is on and the generator is not output, take the following response:

1. Turn off the connected electrical equipment and stop the engine.
2. Reduce the total power of the connected electrical equipment to within the rated output range.
3. Check if the air-conditioning air inlet is blocked the relevant control parts are abnormal, if any problems, immediately excluded.
4. After checking, restart the engine.

**Attention:** When using electrical equipment with higher starting current (such as compressor, submersible pump, etc.), the overload indicator light may turn on for a few seconds, but normal, not the overload fault mentioned earlier.

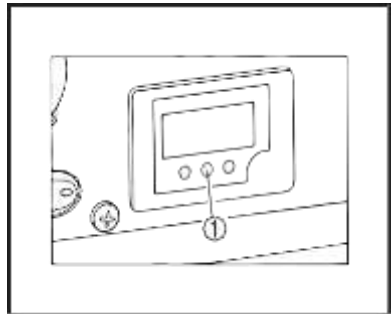

The engine starts and enters normally. When the time, the AC indicator light.

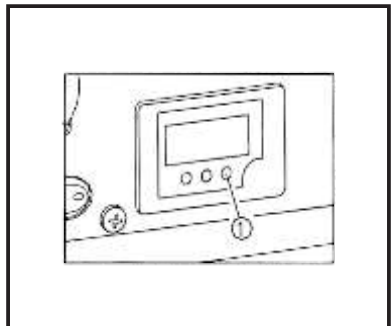

## Frequency switch (100V)

CD 5GHz

® 60Hz

*If to need change the generator output frequency , stop the generator, adjust the position of the frequency switch with a flat screwdriver , and restart the generator.*

**Attention:** *The frequency switch is able to achieve the switching frequency function only when the generator stops. If the generator is running, the output frequency can't be changed .*

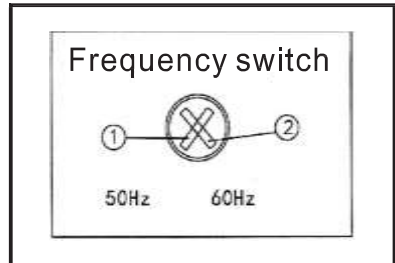

## DC protection

*When the electrical equipment connected to the generator is running, if the current exceeds the rated current , the DC switch automatically pops up. When operating the generator again, press the "ON" position of the DC switch.*

CD ON DC start output.

® OFF DC stop output.

### **Attention:**

*If DC protection is off, reduce the load on the connected electronics to within the generator rated output range. If the DC protection is still off, stop using the appliance directly and consult the dealer .*

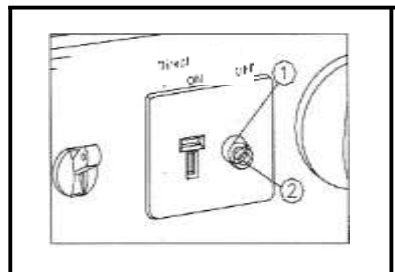

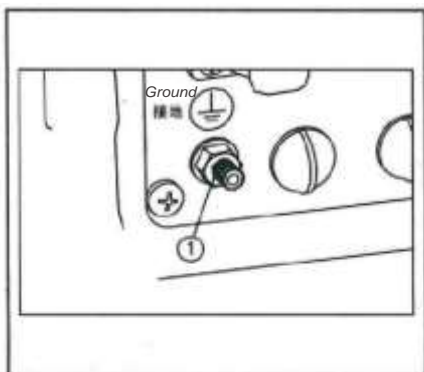

**Ground ①** When connected to the ground wire to prevent electric shock. When the electrical equipment is grounded, the generator must be grounded.

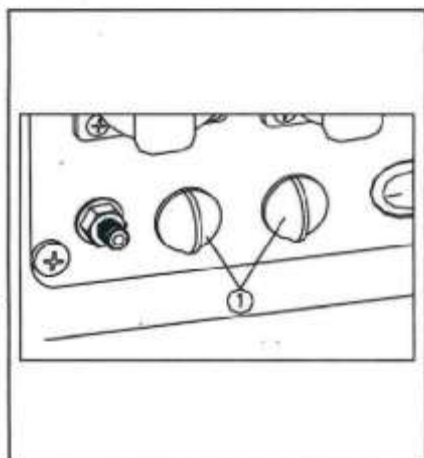

**Parallel terminal G)** used to connect two or more generators in parallel operation of the special cable. Parallel operation requires two or more generators and special cables. (Rated output power of 6kVA in parallel).

The operating procedures and related precautions are detailed in the parallel cable system section. Please consult the dealer about the parallel cable system.

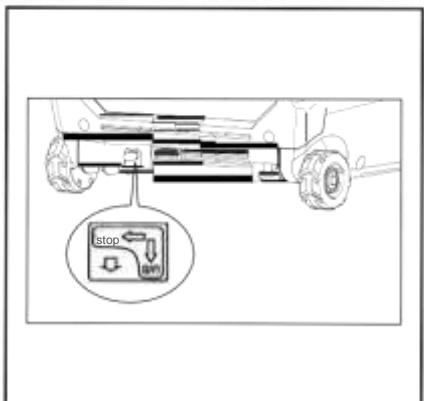

When the generator is running and storing, move the brakes to STOP. To move the generator, set the brake to the RUN stop.

## Check before use

*Be sure to check in advance before use.*

*The engine muffler becomes very hot after the engine is running. When the engine and muffler are not cooled, check and repair, please pay attention to avoid any parts of the body or clothing touch the engine and muffler.*

- Fuel is flammable with drugs, please read care fully before filling the safety requirements.*
- Do not raise the fuel too full, otherwise the fuel tank will overflow the oil tank, make sure the fuel tank cover has been tightened.*
- After refueling, immediately spill the leakage fuel.*
- Must use unleaded petrol, leaded gasoline will seriously damage the internal parts of the engine.*

*Make sure there is sufficient fuel inside the tank.*

*Recommended fuel: unleaded petrol  
Fuel tank capacity Total: 10.0L*

*(J) Fuel indicator*

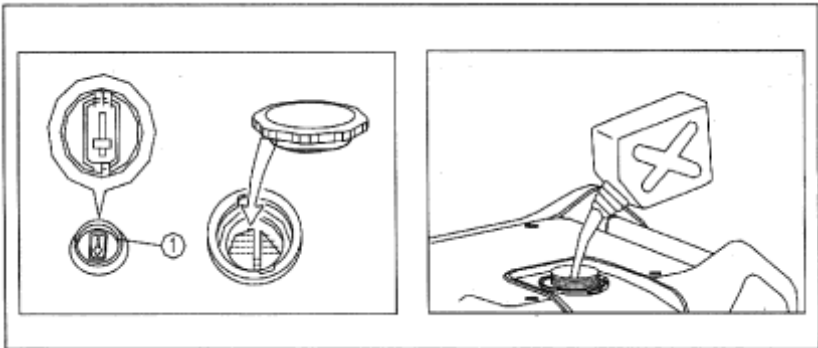

## Engine oil

*The generator is shipped without oil. Do not start the generator before injecting enough oil .*

*When adding oil, do not tilt the generator to prevent excessive oil from damaging the engine .*

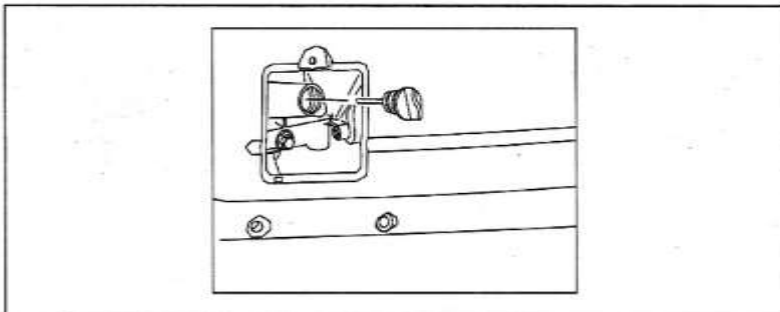

Oil level  
机油液位

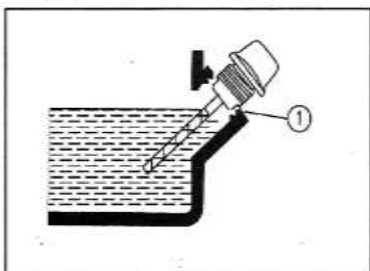

*Recommended oil: SAE  
10KW-30*

*Recommended oil  
grade: AP/ standard SE  
or even higher*

*Oil capacity: 0.6L*

# OPERATE

**Do not use generator in a closed area. Generator exhaust contains carbon monoxide. This is a poison you cannot see or smell. It can cause lose consciousness or death in a short time. Only use OUTSIDE.**

- Generator works in standard atmospheric can output rated power
- The standard atmospheric is : environment temperature 25 °C ,atmospheric pressure 1 00kpa,relative humidity 30%
- The output of generator will be changed according to different temperature ,height and humidity.
- The generator output will be decreased when the temperature, height and humidity is over the standard atmospheric condition.
- When use generator in a small place, it must decrease the load. Because in small place, it will affect the generator cooling.

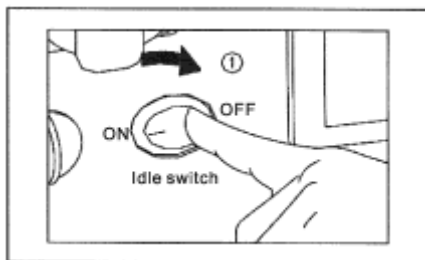

Do not connect any electronic equipment before starting generator. And put the ECO.switch to "OFF" position G)

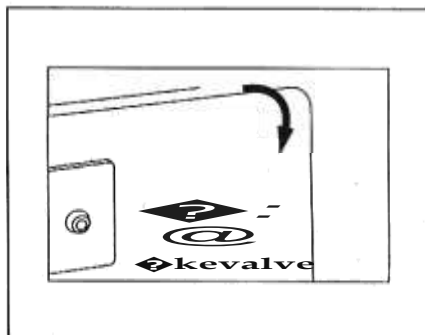

combination switch to "CHOKE" position.  
 A. open the fuel  
 a.open the ignition system  
 C. Choke closed  
**Notice** : If start generator when the engine is hot , do not close choke . Put the combined switch to "ON" position .

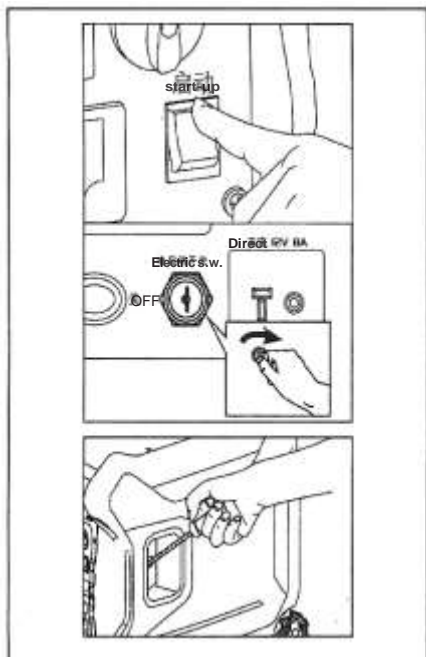

### **Electric start**

Press the button on the control panel to " O N" position.

If generator is e-start, when press the button to "ON" position, the generator will start. In order to lengthen the life of generator , every time when press the button do not over 3 seconds. And the interval time should be more than 10 seconds between two start.

### **Recoil start**

Pull the starting handle slightly first. When you feel the recoil force, pull the starting handle forceful

**Notice** : Hold the handle of inverter generator when pull the starting handle . It is to prevent the generator tip-off.

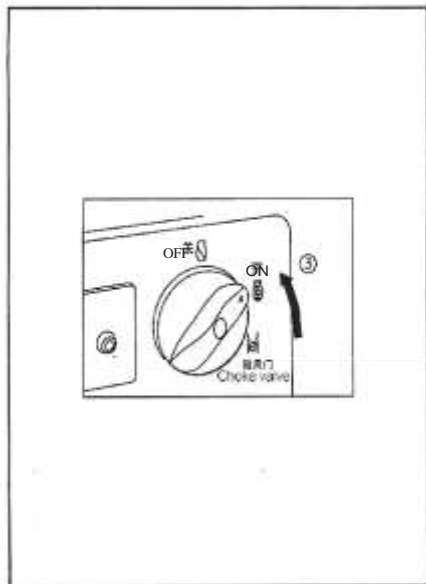

Preheat the generator and then put the combination switch to " ON" position.

### **Notice:**

- When start the generator, if the ESC switch is on " ON " position , generator cannot connect any load.
- When the environment temperature is lower than 0 °C ( 32F ) , the RPM of engine is 3600 rpm, preheat time is 5 mins. When environment temperature is lower than 5 °C ( 41F ) , the RPM of engine is 3600 rpm, preheat time is 3 mins. After running above mentioned preheattime, generator can work when ESC switch is on "ON" position.

# STOP THE ENGINE

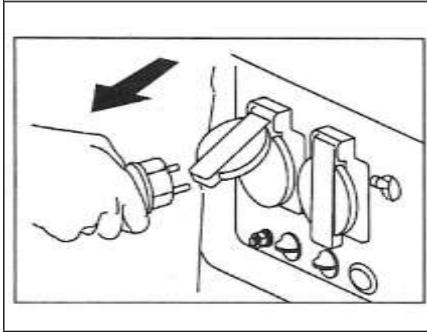

*move the load.*

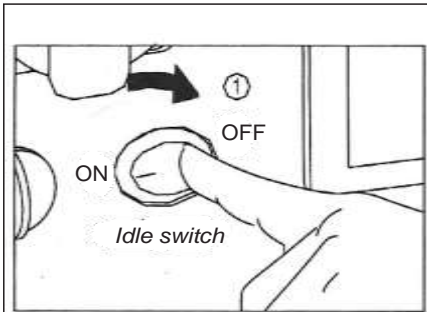

*Notice: Turn off all the electronic equipment.*

- 1. put the ESC switch to "OFF" position*
- 2. turn off all the electronic equipment.*
- 3. twist the combination switch to "OFF" position*
  - a. Close the fuel.*
  - b. Close the ignition system.*

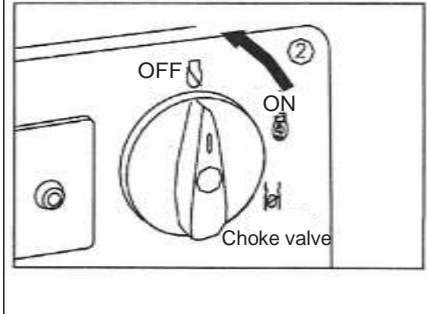



# AC CONNECTION

*All the electronic equipment should be turn off before inserting the plug.*

- NOTICE** :
- Make sure all the electronic equipment , including wire and plug are good before connecting to generator.
  - Make sure the total load is within rated power of generator.
  - Make sure the current of load is within the current of

**NOTICE:** Make sure generator has been grounded. If equipment is required to be grounded, generator must be grounded.

1. Start the generator.
2. Put the ESC switch to "ON" position.
3. Insert the plug to AC socket
4. Make sure the AC light is working.
5. Turn on the electronic equipment.

**NOTICE:** Before increasing the RPM of generator, ESC switch must turn to "OFF" position .

- Overload indicator (red) will light up when generator start. Normally, overload indicator (red) will go out within 4 seconds . If the overload indicator (red) light all the time, please consult your generator dealer .
- If there are several loads or equipments connected on the generator at the same time, make sure firstly start the equipment that with highest starting current, then middle one, finally to the lowest starting current one.
- When generator running overload or the connecting equipment short circuit, overload indicator(red) will light up. About 4 seconds, the generator output indicator(green) will go out, generator is no voltage output. Stop generator and check whether it is caused by overload running or connected equipment is short circuit. Start the generator again after solving the problem.

## **battery charge**

### **Notice**

- The DC is 12V
  - Connect the battery to Generator after starting generator.
  - Make sure the DC protector is turn on before charging .
1. Start generator
  2. Connect the red guide line to battery positive terminal(+)
  3. Connect the black guide line to battery negative terminal(-)
  4. Put ESC switch to "OFF" position and begin to charge.

**NOTICE**

- Make sure the ESC switch is on "OFF" position when charge the battery.
- Make sure charger red guide line is connected to the positive terminal of battery. Black guide line is connected to the negative terminal of battery. Do not be inversed .
- Make sure it is connected tightly between charger and battery to avoid getting loose when generator vibrates.
- Operate in a correct way according to the owner's manual.
- If the current is over rated current during charging, DC protector will close the output. Put the DC protector to "ON" position to recharge again. If DC protector close again , please stop charge and contact with your supplier.

**Notice:**

*User according to the introduction as below to check whether battery is charged full.*

- Measuring the electrolyte density to determine whether the battery has been completely filled. If completely filled , electrolyte proportion is between 1.26 and 1.28 and voltage is above 12.5 V.
- Suggest at least every 1 hour to check the electrolyte density , in order to prevent the battery is too full.

- In the process of charging , please do not smoke ,
- connect or disconnect the battery . As the spark will
- ignite the gas around battery.
- Battery electrolyte contains sulfuric acid which is
- toxic and danger of burns . Please avoid contact with
- skin, eyes and clothing.

**Therapeutic method:**

*Exocontact--- Flush with plenty of water*

*If swallow, please drink water or milk right away. Or drink milk containing magnesium oxide , egg liquid or vegetable oil and go to hospital immediately.*

*Eye contact---Flush with water . Then go to hospital immediately.*

*The battery can produce explosive gas , please stay away from sparks , flame , cigarettes , etc . Charge or use in closed Spaces , please keep the ventilation . When work close to the battery ,please try to close your eyes*

**Please put battery out of reach of children.**

## Parallel function

Make sure the generator works well before connecting electronic equipment to generator. The total load of equipment can not more than generator rated power .

1. Use professional cable kit to parallel two generators.
2. Start the generator in turn and make sure each generator's output indicator light(green) is on.
3. Insert the equipment plug to the generator socket
4. Start the equipment.

## AC parallel operation equipment





### Notice:

- Make sure all the electronic equipment ,including guide line and socket are in good condition .
- When some equipment operates unusual ,becomes slow or even stop, turn off the power immediately. Disconnect the equipment , and check whether the equipment or the generator rated power is already over.
- Make sure that the total load of parallel equipment is not over the rated power of generator.
- Within max power, only can work not more than 30 mins . Do not parallel different model generator
- When parallel generator , only can use the cable kit from **OINKING**.
- Never disconnect or connect cable when generator is running .
- Must disconnect the cable when only one generator running .

- Run overload for a long time , and overload indicator light (red) lights up continuously, can damage the generator. Overload sli ghtly , overload indicator light (red) flashing lights up , may shorten the life of generator. .
  - Only can running last 30 minutes at the max power of generator
  - Do not over the rated power if continuously running
  - The rated power is 6KW if two generator
- .....Pc3.r.c1//€J/€Jcl.

## Application scope

Before using the generator, please make sure the total load within the range of rated output of generator, or it will damage the generator.

AC				DC 
Power factor	1	0.8-0.95	0.4-0.75 (Efficiency 0.85)	
3300i	<3000W	<2400W	<1200W	Rated voltage 12V Rated current 8A

### NOTE:

- " " meaning less than.
- Each equipment is working ,there will be show the data of power output .
- AC and DC can be used at the same time, but the total power could not exceed the rated output power.

### For example:

Generator rated output		3000VA
operating ratio	power factor	
AC	1.0	≤ 3000W
	0.8	≤ 2400W
DC	--	96W(12V/8A)

When the total power over rated level , the overload indicator will working.

### NOTICE

- Do not running over load. Total power of equipment can't exceed the output power of generator. Overload will damage the generator.
- Using generator supply power to the precision instrument, electronic controller, personal computers, electronic computer etc. Please keep enough distance between equipment and generator , prevent the electromagnetic interference of engine . At the same time also ensure that the engine is not affected by the interference of other electronic facilities.

- Using this generator power supply for medical equipment, please consult equipment supplier, professional person and hospital first.
- Some electronic devices or general motor in need large current when starting, lead to can't use. Even if it's launch parameters satisfy as described above. Please contact the equipment manufacturer.

## Maintenance

The user should operate the machine safely. Periodic checking, adjust and lubrication can ensure the generator is more efficient work in safety. The following is the important checking items to generator:

■ If you are not familiar with maintenance work, please delivery to dealer to service for you.

## Maintenance Item

■ Please turn off the engine before maintenance.

Can only be replaced with specified genuine spare parts, please contact with DK dealers for specific attention.

Item	Routine checking	Check before use (each day)	Each 6 months or 100 hours	Each 12 months or 300 hours
Spark	Check status, clean or replace if necessary		○	
Fuel	Check fuel level and leakage	○		
Fuel tube	Check the tube for cracks or damaged replace if necessary	○		
Oil	Check oil level	○		
	Replace		○(1)	
Air cleaner	Check status, clean		○(2)	
Muffler cover	Check status, clean or replace if necessary		○	
Spark collector	Check status, clean or replace if necessary		○	
Fuel filter	Check status, clean or replace if necessary			○
Crankcase breather tube	Check the tube for cracks or damaged replace if necessary			○
Cylinder cover	If necessary, clean carbon			★
Valve gap	Check and adjust the engine after cooling			★
Mounting parts	Check and adjust mounting parts, replace if necessary			★
Find out the problem before using		○		

(1) Changing oil before one month at the first time or 20 hours later.

(2) Cleaning air filter frequently when used in wet or dusty

\* environment.

Above maintenance project should be proceed by dealer.

## Spark plug check

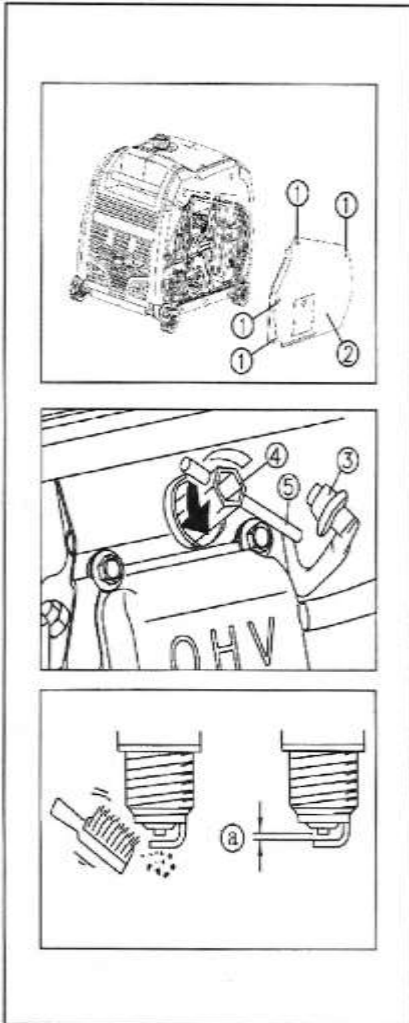

The spark plug is one of the important parts to engine , must be checked regularly.

1. Loosen the screws (G) , Remove the cover (R) .
2. Remove the spark plug cap (R) , Place the sleeve (R) to the spark plug suitable position
3. Insert the screwdriver @ into the sleeve inside , counterclockwise , and then remove the spark plug .
4. Checking if there is fade , timely removal of carbon, the spark plug center around the electrode porcelain heart should be show a moderate shallow brown.
5. Checking spark plug type and clearance

Standard spark plug: BPR6ES/BP6ES(NGK)  
F6RTC1 F6TC  
The spark plug clearance: 0.7- 0.8

6. Install the spark plug.  
Tips: When installing the spark plug without a torque wrench , a better solution is a hand to twist 1/4 ~ 1/2 turn . But the spark plug should be tightened to the specified torque as soon as possible.
7. Install the spark plug cap and cover
8. Install the cover.

## Adjust the carburetor

The carburetor is an important part of engine. Adjust the carburetor shall be operated by dealer , to ensure that the correct adjustment.

## Clean the fuel filter

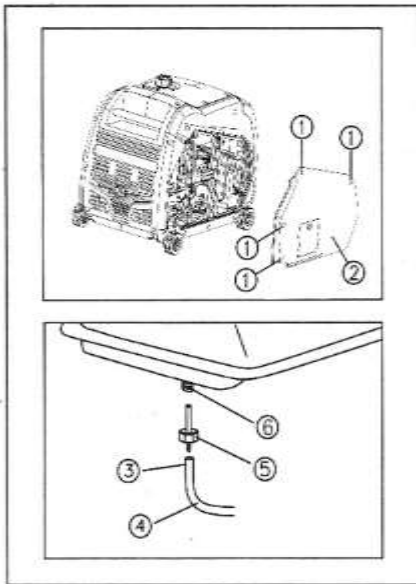

remove the cover

2. Empty the fuel tank, hold clamp, making clamp down and then pull down connected to the fuel tank.

3. Remove the fuel pipe, take out the fuel filter and clean the fuel filter in the non-combustible or high flash point solvent.

4. Install the air filter into the fuel tank of the nozzle, then tubing set on the fuel tank out of the nozzle, and fix the clamp.

## Change Oil

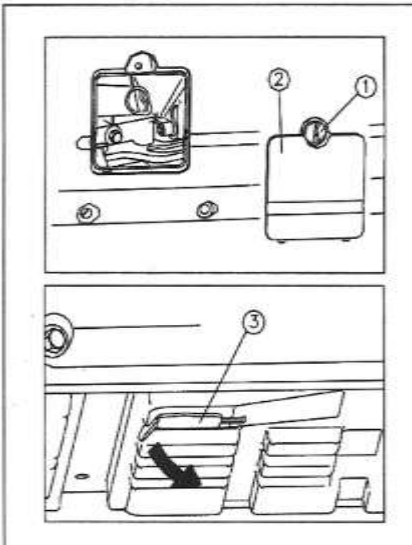

Do not discharge the oil immediately after shut down the generator. The oil temperature is high, must be noticed when operating in order to avoid scald.

1. Place the generator in a horizontal plane, and start the generator for a few minutes, increase the temperature, and then stop the engine.

2. Loosen the oil window handle, remove the oil window.

3. The machine is raised tilt, remove oil drain rubber pad on the base of machine.

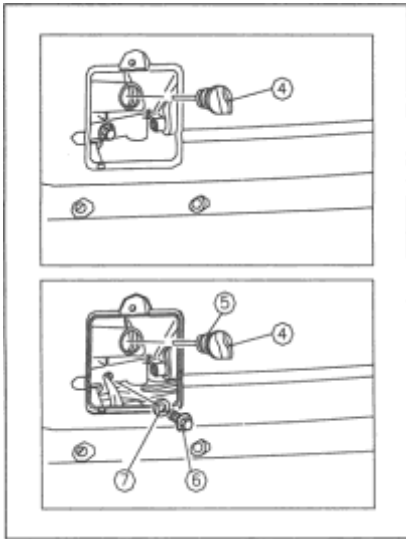

4. Remove the oil gauge (R) o
5. Place the oil basin below the machine base plate , take oil bolt down (4), the oil will outflow from the crankshaft o
6. Check the oil gauge (R) seal (4) oil drain bolt (4) gasket (J) .If there are any damage, please change immediately.
7. Reinstall the oil drain bolt and seal o
8. To refill the oil to the appropriate location ,tighten the oil gauge o
9. Install the oil window o
10. Install the base of machine and drain rubber gasket o

**NOTICE**

- Do not tilt the machine when adding oil to prevent add too much oil and damage the engine o
- Do not make other items into the crankcase .

**Air cleaner**

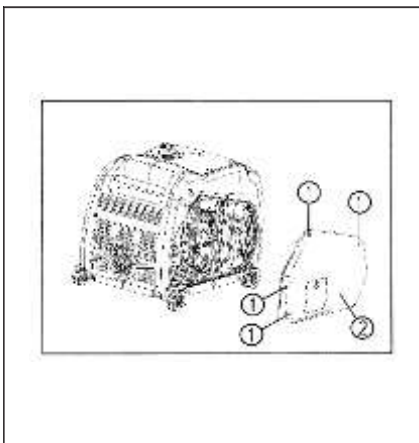

1. Loosen the screws (G) Remove the cover (2)



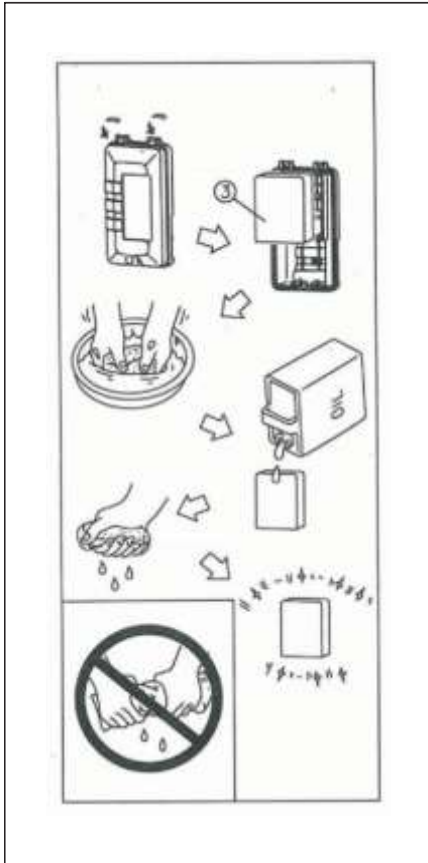

2. Remove the air filter and foam filter

3. Cleaning the foam filter by solvent and drying

4. To add gasoline on the foam filter and then squeeze out the extra oil, the foam filter should be wet, but not drip, do not forcibly twisting foam filter, to avoid damage

5. Put the foam filter into the air cleaner.

TIPS: To confirm the surface of the foam filter and air cleaner is clingy, do not leave gaps leak. Do not start the engine before install the air cleaner. Because there will be produce excess poison gas and wear cylinder.

6. Install the air cleaner in the original position.

## The muffler cover

After the engine running, the engine and muffler become very hot, when the inspection and maintenance, please do not make your skin and clothes directly touching the engine and muffler.

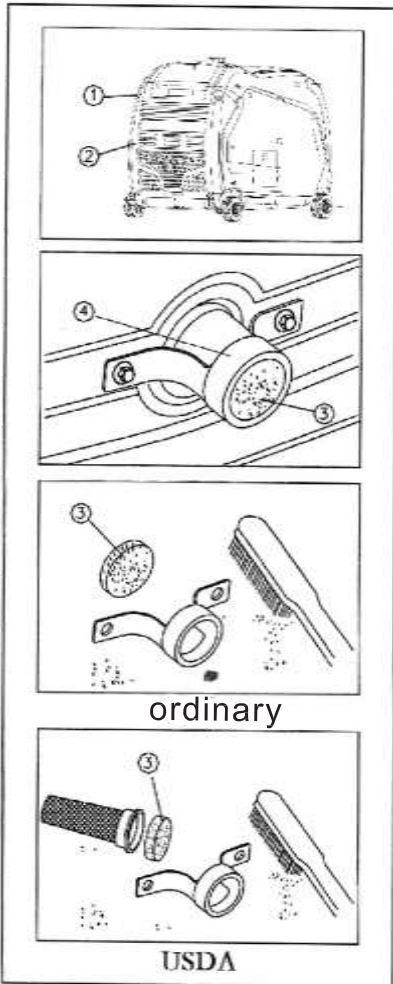

1. Loosen the screw (G), remove the end cover (R) (O)
2. Take out the net cover of the muffler (A), remove the spark collector (A) (O)
3. Clean the carbon deposit on the muffler net cover with a brush.
4. Check the muffler net, if there is damage, please replace immediately (Y)
5. Reinstall the spark collector.

## **Keeping Custody**

*If will store this genset for a long time, in order to avoid the aging, you need to do some keeping measures.*

*Evacuate the fuel*

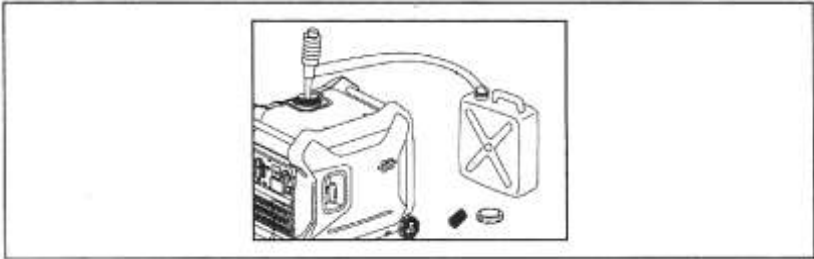

- 1 Turn the three in one control switch button to the "off" position .*
- 2 Open the fuel tank gasket , lift out the filter , fully extract the fuel to the specially fuel tank and put on the fuel tank gasket .*
- 3 The fuel easy to volatilizied with poison , please carefully read the "Safety Notifcation "and use the soft clean fabric to erase the drain out fuel , prevent damage the plastic outer cover.*
- 4 Start the engine , about 20 minutes later the fuel finish and the engine will be stop.*

### **Mention:**

- Please do not connect any appliance.*
  - The engine running time depend on the surplus fuel.*
- 5 Loosen the oil drain bolt of carburetor , put the fuel of carburetor into the specially fuel tank.*
  - 6 Turn the three in one control switch to the "Off" position.*
  - 7 Tightening the oil drain bolt.*

## **Engine:**

Following the below steps to protect the crankcase, piston ring ect easy corrosion spare parts:

- 1 Put off the spark plug, pour into the 10mL SAE10W30 lubrication oil and put on the spark plug.
- 2 Pull the recoil starter several minutes , make the oil lubricate the cylinder .
- 3 Pull the recoil starter until you feel tightening(avoid the crankcase and valve rust).
- 4 Stop pulling.
- 5 Clean the engine outside parts and spray antirust agent.
- 6 Put this genset to the dry and ventilation place and cover it with canvas .
- 7 Must vertical flat place this genset.

## **Failure Remove:**

### **Can not start the engine**

- 1 Fuel system
  - Fuel filter was blocked, cleaning the fuel filter.
  - Carburetor was blocked, cleaning the carburetor.
- 2 Oil system
  - Oil level too low, pour into the oil.
- 3 Electrical system
  - Combination switch which be switched to "Choke", recoil start is ok, spark plug without Ign ition.
  - Spark plug with carbon deposition and humidity, cleaning spark plug, dry to spark plug
  - Ignition system problem please contact distributor.

### **Generator Without Voltage Output:**

- Safety device(DC protector) at the "Off" position, push down the DC protector at the " On" position.
- AC indicator (green) extinguish , stop the engine and restart.

## TECHNICAL PARAMETER

ITEM		PARAMETER
GENERATOR	Model	3300i
	Type	Inverter
	Frequency/Hz	50/60/50&60
	Rated Voltage/V	100/120/230
	Max Output Power/KVA	3.3
	Rated Output Power/KVA	3.0
	Power Factor	1.0
	AC Output Standard	ISO8528G2
	Waveform Deviation Factor	<5
	Noise(dB)(7m)	65
	DC Output	12V/8A
	Overload Protection	DC
AC		Inverter Over-current Protection Program Control
ENGINE	Model	170FDIP-2
	Type	Single Cylinder/4 Stroke/Forced Air Cooling/OHV
	Displacement	212cc
	Fuel Type	Vehicle-use Unleaded Gasoline
	Fuel Tank Capacity	10L
	Continuous Working Period	5.5h
	Lubrication Oil Capacity	0.6L
	Spark Plug Model	BPR6ES/BP6ES(NGK)F7RTC/F7TC
	Starting Mode	Recoil/Electric
Dimension(Lx WxH)		620x45Bx520mm
<b>N.W(kg)</b>		

(C) T  
 eV

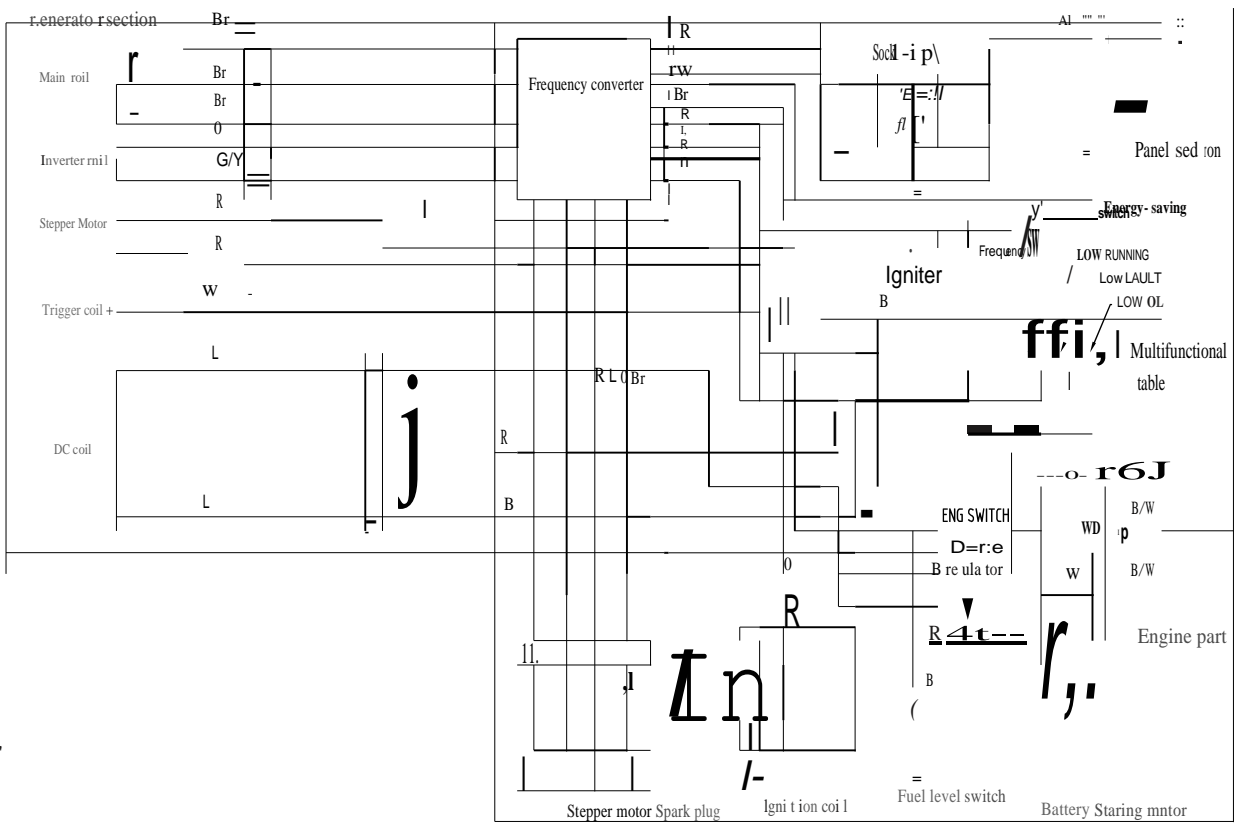

(C) T

AC  
N  
V

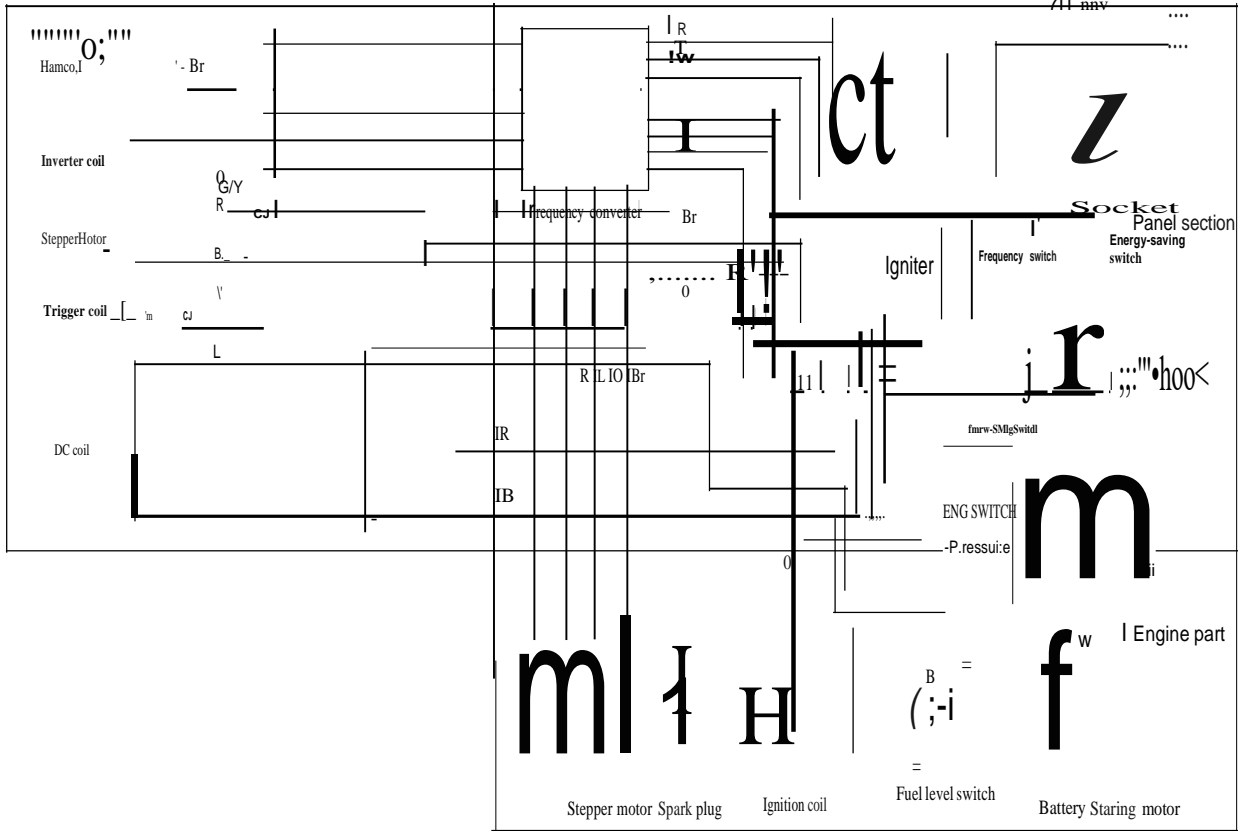

L(D)  
(C)

Generator section

Br -

Main coil

$\bar{I}$

Br -  
Br -  
0

Inverter coil

G/Y -

Stepper Motor

R -  
W

R

I R

L

W

Frequency converter

Br  
H  
n  
I

9<sup>9</sup>



Panel section

Energy-saving

galer n

i' /  
switch

Frequency ";, LOW RUNMNG

<



‘ ‘ ‘

LOW LAULT

<

\_J:\_

::

R L 0 Br

L

=

j

1

Trigger coil

B

/OW<sub>OL</sub>

<

..

f.

|

fr

••

Multifu

nctional

<

|

|

table

<

CD

<

<

<

<



<



