



**BN PRODUCTS-USA, LLC.**

A Division of Benner-Nawman, Inc.

# Assembly Instructions

## BNMS-100B Mixing Station



1. Check the package you received to ensure all parts are included. If any parts are missing do not return this product to the store but contact BN Customer Service at 1-800-992-3833.

2. To attach the Casters (#1) turn the Lower Frame Assembly (#5) upside down on a level surface. The two locking casters need to be installed in the back of the frame that is near the Foot Lock Lever (#4). Use a 3/4" open end wrench and a 3/4" socket to install the casters. Install a wheel bolt and washer up through the Lower Frame (#5) and through the Caster and attach with a Lock Nut (#3) on each wheel.

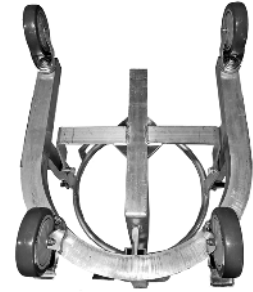

Diagram A

3. Place the Back Plate (#22) inside the Bucket Frame (#21) with the threaded stud sticking out of the bottom hole and loosely start the Wing Nut (#27). Thread the Lock Handle (#26) through the Bucket Frame and into the Back Plate but leave loose. See Diagram B.



Diagram B

4. With the Back Plate (#22) very loose slide the Extension Frame (#8) into the Bucket Frame and lock into place about 4 inches from the bottom.

5. Slide the Extension Tube (#10) with swivel into the Extension Frame and lock in place with the Pin (#9). See Diagram C.

6. Attach the two Knob Bolts (#13) to the Swivel Assembly.

7. Install the battery in the Timer and attach it to the back bracket.

8. The electric mixer can now be installed and the Swivel adjusted with the Bottom Knob (#18).

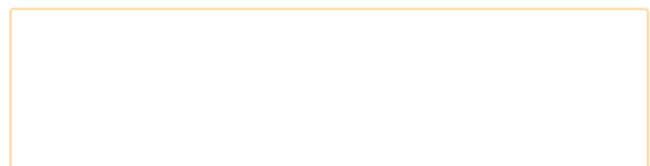

Diagram C

**Note: When attaching an electric mixer, the paddle will need to be pushed up through the Swivel and threaded into the mixer.**

BNMS100B Assembly Instructions.indd

**BN Products-USA, LLC.**  
3450 Sabin Brown Road  
Wickenburg, AZ 85390  
(800) 992-3833  
mail@bnproducts.com





**BN PRODUCTS-USA, LLC.**

A Division of Benner-Nawman, Inc.

# Assembly Instructions

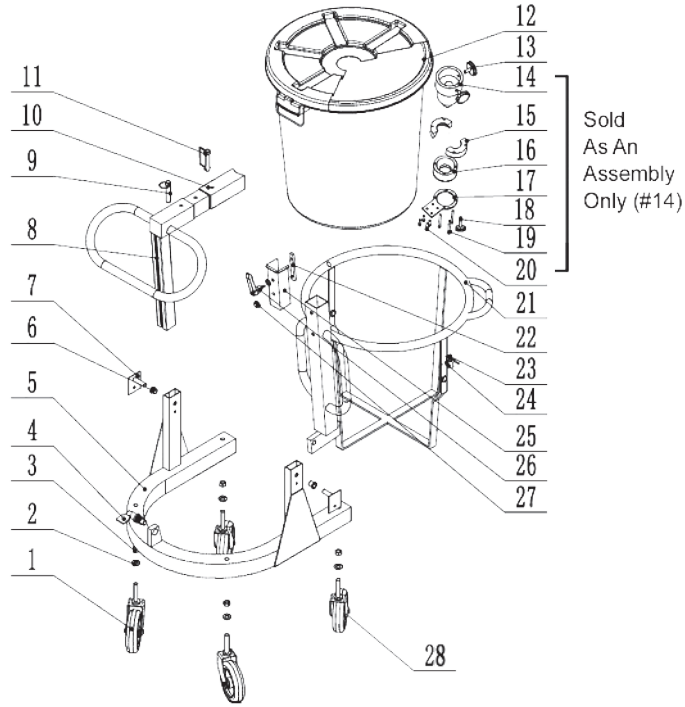

No.	DESCRIPTION	PART No.
1	CASTER BNMS-100B NON LOCKING	101113
2	WASHER BNMS-100B	101114
3	LOCK NUT BNMS-100B	101115
4	PIN BNMS-100B	101116
5	STAND BNMS-100B	101117
6	SLEEVE BNMS-100B	101118
7	ROTATING SHAFT BNMS-100B	101119
8	EXTENSION FRAME BNMS-100B	101120
9	PIN BNMS-100B	101121
10	EXTENSION TUBE BNMS-100B	101122
11	HOOP PIN BNMS-100B	101123
12	BUCKET BNMS-100B	101124
13	BAKELITE BOLT M8 BNMS-100B	101125
14	SWING AXLE ASM BNMS-100B	101126

No.	DESCRIPTION	PART No.
15	UPPER BALL BNMS-100B	101127
16	LOWER BALL BNMS-100B	101128
17	MOUNTING PLATE BNMS-100B	101129
18	BAKELITE BOLT M6 BNMS-100B	101130
19	HEX BOLT M8 X 30 BNMS-100B	101131
20	HEX BOLT M8 X 15 BNMS-100B	101132
21	FRAME BNMS-100B	101133
22	BACK PLATE BNMS-100B	101134
23	HOOK BNMS-100B	101135
24	RND HD BOLT M6 X 12 BNMS-100B	101136
25	PROTECTION BOARD BNMS-100B	101137
26	LOCK BOLT BNMS-100B	101138
27	NUT M6 BNMS-100B	101139
28	CASTER BNMS-100B LOCKING	101113L