



BN Products-USA™

A DIVISION OF BENNER-NAWMAN, INC.

WWW.BNPRODUCTS.COM

OPERATING INSTRUCTIONS

BNG SERIES GASOLINE GENERATORS

Customer Service: (800) 992-3833

BNG-SERIES GASOLINE GENERATORS

OPERATOR INSTRUCTION MANUAL

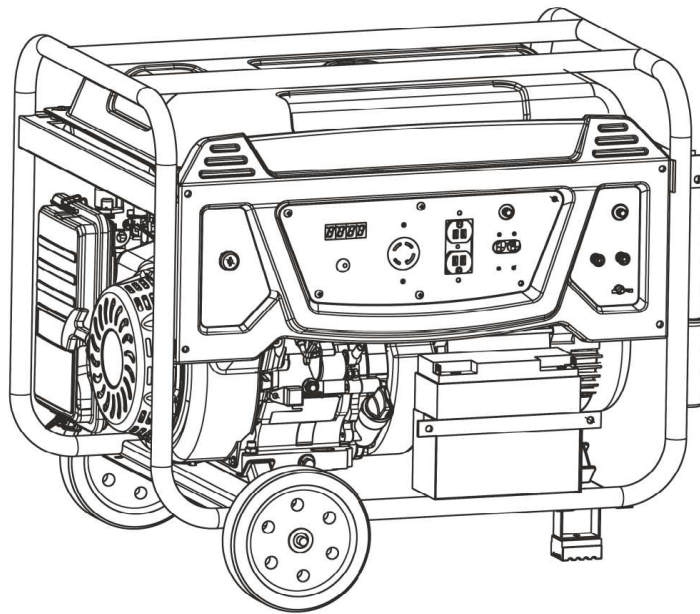

MODELS

BNG3000 (3KW)

BNG5000 (5KW)

BNG6500 (6.5KW)

BNG7500 (7.5KW)

BNG7500-D4 (7.5K)

BNG9000 (9KW)

BN Products-USA™

3450 N. SABIN BROWN ROAD
WICKENBURG, AZ 85390

CUSTOMER SERVICE: (800) 992-3833



FAX: (928) 684-7041

WWW.BNPRODUCTS.COM



BN Products-USA™

A DIVISION OF BENNER-NAWMAN, INC.

WWW.BNPRODUCTS.COM

OPERATING INSTRUCTIONS

BNG SERIES GASOLINE GENERATORS

Customer Service: (800) 992-3833

Contents

INTRODUCTION.....	3
SAFETY RULES	3
ADDING OR DRAINING FUEL	4
SECTION 2 - GENERAL INFORMATION.....	5
2.1 - UNPACKING.....	5
2.1.1 PACKING CONTENTS	5
2.2 - ASSEMBLY	5
2.2.1 - ASSEMBLING THE ACCESSORY KIT	5
SECTION 3 - FEATURES AND CONTROLS	6
Parts of Generators	6
SECTION 4 - PREPARATION BEFORE OPERATION	6
4.1 - ADDING ENGINE OIL	6
4.2 - ADDING FUEL	7
4.3 - GROUNDING THE GENERATOR.....	7
WATTAGE REFERENCE GUIDE	8
SECTION 5 — OPERATION.....	8
5.1 STARTING THE ENGINE.....	8
5.2 - CONNECTING ELECTRICAL LOADS	10
5.3 - STOPPING THE ENGINE	10
5.4 - LOW OIL LEVEL SHUTDOWN SYSTEM.....	10
5.5 - HIGH ALTITUDE.....	10
SECTION 6 - MAINTENANCE	11
6.1 - MAINTENANCE SCHEDULE	11
6.2 - GENERAL RECOMMENDATIONS.....	11
6.2.1 - GENERATOR MAINTENANCE.....	11
6.2.2 - TO CLEAN THE GENERATOR	11
6.2.3 ENGINE MAINTENANCE	12
6.2.4 CHANGE OIL.....	12
6.2.5 REPLACE THE SPARK PLUG.....	12
6.2.6 SPARK ARRESTOR	12
6.3 SERVICE AIR FILTER.....	12
6.4 - VALVE CLEARANCE	13
6.5 - GENERAL	13
SECTION 7 - STORAGE	13
SECTION 8 - WARRANTY.....	14
SECTION 9 - TROUBLESHOOTING	15



BN Products-USA™

A DIVISION OF BENNER-NAWMAN, INC.

WWW.BNPRODUCTS.COM

OPERATING INSTRUCTIONS

BNG SERIES GASOLINE GENERATORS

Customer Service: (800) 992-3833

INTRODUCTION

Thank you for purchasing products by our company, we appreciate your business. The generator is a compact, high performance, air-cooled, engine driven generator designed to supply electrical power to operate electrical loads on job sites, or remote locations where utility power is available or in place of a utility due to a power outage.

This manual contains safety information to make you aware of hazards and risks associated with our generator products and how to avoid them. It is important that you read and understand these instructions thoroughly before attempting to start or operate this equipment. Save this original instruction manual for future reference.

If any portion of this manual is not understood, contact the nearest authorized dealer for starting, operating and servicing procedures. We also strongly recommend instructing other users to properly start and operate the unit. This prepares them if they need to operate the equipment in an emergency.

The Emission Control System for this generator is warranted for standards set by the Environmental Protection Agency and also the California Air Resources Board.

Every effort has been made to ensure that information in this manual is both accurate and current. However our company reserves the right to change, alter or otherwise improve the generator and this documentation at any time.

SAFETY RULES

Read this manual carefully and become familiar with your generator. Know its applications, its limitations and any hazards involved.

Throughout this publication, and on tags and decals affixed to the generator, DANGER, WARNING, CAUTION and NOTICE blocks are used to alert personnel to special instructions about a particular operation that may be hazardous if performed incorrectly or carelessly. Observe them carefully. Their definitions are as

follows:

DANGER - indicates a hazard which, if not avoided, will result in death or serious injury.

WARNING - indicates a hazard which, if not avoided, could result in death or serious injury.

CAUTION - indicates a hazard which, if not avoided, could result in minor or moderate injury.

NOTICE - address practices not related to personal injury.

WARNING - Running gasoline engines gives off carbon monoxide, an odorless, colorless, poisonous gas. Breathing carbon monoxide could result in death, serious injury, headache, fatigue, dizziness, vomiting, confusion, seizures, nausea or fainting.

- Operate this product **ONLY** outdoors.
- Install a battery operated carbon monoxide alarm near any closet or any nearby bedrooms.
- Keep exhaust gas away from entering a confined area through windows, doors, ventilation intakes, or other openings.
- **NEVER** operate this product inside any building, carport, porch, mobile equipment, marine applications, or enclosure, even if windows and doors are open.

PLEASE NOTE!

Using a generator indoors
CAN KILL YOU IN MINUTES
Generator exhaust contains carbon monoxide.
This is a poison you cannot see or smell



Never use inside a home or garage even if the doors and windows are open



Only use outside and far away from doors and vents



WARNING - The engine exhaust from this product, certain components in this product and related accessories, contain chemicals known to the State of California to cause cancer, birth defects or other reproductive harm. Wash hands after handling.



BN Products-USA™

A DIVISION OF BENNER-NAWMAN, INC.

WWW.BNPRODUCTS.COM

OPERATING INSTRUCTIONS

BNG SERIES GASOLINE GENERATORS

Customer Service: (800) 992-3833

WARNING - This generator does not meet U.S. Coast Guard Regulation 33CFR-183 and should not be used in marine applications. Failure to use the appropriate U.S. Coast Guard approved generator could result in death or serious injury and/or property damage.

WARNING - Starter cord kickback (a rapid retraction) will pull hand and arm toward engine faster than you can let go which could cause broken bones, fractures, bruises, or sprains resulting in serious injury.

- When starting engine, pull cord slowly until resistance is felt and then pull rapidly to avoid kickback.
- NEVER start or stop engine with electrical devices plugged in and turned on.

WARNING - Fuel and its vapors are extremely flammable and explosive which could cause burns, fire or explosion resulting in death, serious injury and/or property damage. See Cal Prop 65 info on page 16

ADDING OR DRAINING FUEL

- Turn generator engine OFF and let it cool at least 2 minutes before removing fuel cap. Loosen cap slowly to relieve pressure in tank.
- Fill or drain fuel tank outdoors only.
- DO NOT overfill tank. Allow space for fuel expansion.
- If fuel spills, wait until it evaporates before starting engine.
- Keep fuel away from sparks, open flames, pilot lights, heat, and any other ignition sources.
- Check fuel lines, tank, cap and fittings frequently for cracks or leaks. Replace if necessary.
- DO NOT light a cigarette or smoke.

WHEN STARTING EQUIPMENT

- Ensure spark plug, muffler, fuel cap, and air cleaner are in place.
- DO NOT crank engine with spark plug removed.

WHEN OPERATING EQUIPMENT

- DO NOT operate this product inside any building, carport, porch, mobile equipment, marine applications, or enclosure.

- DO NOT tip engine or equipment at an angle which could cause fuel to spill.
- DO NOT stop engine by moving choke control to "OFF" position.

WHEN TRANSPORTING, OR REPAIRING EQUIPMENT

- Transport/move/repair with fuel tank EMPTY and with the fuel valve OFF.
- DO NOT tip engine or equipment at angle which cause fuel to spill.
- Disconnect spark plug wire.

WHEN STORING FUEL OR EQUIPMENT WITH FUEL IN TANK

- Store away from furnaces, stoves, water heaters, clothes dryers, or other appliances that have light or other ignition source because they could ignite fuel vapors.

WARNING - Generator voltage could cause electrical shock or burn resulting in death or serious injury.

- Use approved transfer equipment to prevent back feed by isolating generator from electric utility workers.
- When using generator for backup power, notify utility company.
- Use a ground fault circuit interrupter in any damp or highly conductive area, such as metal decking or steel work.
- DO NOT touch bare wires or receptacles.
- DO NOT use generator with electrical cords which are worn, frayed, bare or otherwise damaged.
- DO NOT operate generator in the rain or wet weather.
- DO NOT handle generator or electrical cords while standing in water, while barefoot, or while hands or feet are wet.
- DO NOT allow unqualified persons or children to operate or service generator.

WARNING - Exhaust heat/gases could ignite combustibles, structures or damage fuel tank causing a fire, resulting in death, serious injury and/or property damage. Contact with muffler area could cause burns resulting in serious injury.

- DO NOT touch hot parts and AVOID hot exhaust



BN Products-USA™

A DIVISION OF BENNER-NAWMAN, INC.

WWW.BNPRODUCTS.COM

OPERATING INSTRUCTIONS

BNG SERIES GASOLINE GENERATORS

Customer Service: (800) 992-3833

gases.

- Allow equipment to cool before touching.
- Keep at least 5 feet (1.5 m) of clearance on all sides of generator including overhead.
- Replacement parts must be the same and installed in the same position as the original parts.

CAUTION - Excessively high operating speeds could result in minor injury and/or generator damage. Excessively low speeds impose a heavy load.

- DO NOT tamper with governor spring, links or other parts to increase engine speeds. Generator supplies correct rated frequency and voltage when running at governed speed.
- DO NOT modify generator in any way.

NOTICE - Exceeding generators wattage/ amperage capacity could damage generator and/or electrical devices connected to it.

- DO NOT exceed the generator's wattage/ amperage capacity. See Don't Overload Generator in the Operation section.
- Start generator and let engine stabilize before connecting electrical loads.
- Turn electrical loads OFF and disconnect from generator before stopping generator.

NOTICE - Improper treatment of generator could damage it and shorten its life.

- Use generator only for intended uses.
- If you have questions about intended use, ask dealer or contact local service center.
- Operate generator only on level surfaces.
- DO NOT expose generator to excessive moisture, dust, dirt, or corrosive vapor.
- DO NOT insert any object through cooling slots.
- If connected devices overheat turn them off and disconnect them from generator.
- Turn off generator if:
 - electrical output is lost.
 - equipment sparks, smokes, or emits flames.
 - or unit vibrates excessively.

SECTION 2 - GENERAL INFORMATION

2.1 - UNPACKING

- Set the carton on a rigid flat surface.
- Remove everything from carton except generator.
- Open carton completely by cutting each corner from top to bottom.
- Leave generator on carton to install wheel kit.

2.1.1 PACKING CONTENTS

- Owner's Manual
- Wheels
- Wheel Axle
- Plugs
- Hardware Bag - (including 1-Spark Plug Socket; 1-Extension handle)

2.2 - ASSEMBLY

The generator requires some assembly prior to using it.

2.2.1 - ASSEMBLING THE ACCESSORY KIT

The wheels are designed to fit on the unit to greatly improve the portability of the generator.

NOTE - The wheels are Not intended for over-the-road use.



BN Products-USA™

A DIVISION OF BENNER-NAWMAN, INC.

WWW.BNPRODUCTS.COM

OPERATING INSTRUCTIONS

BNG SERIES GASOLINE GENERATORS

Customer Service: (800) 992-3833

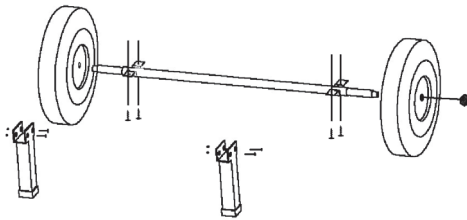
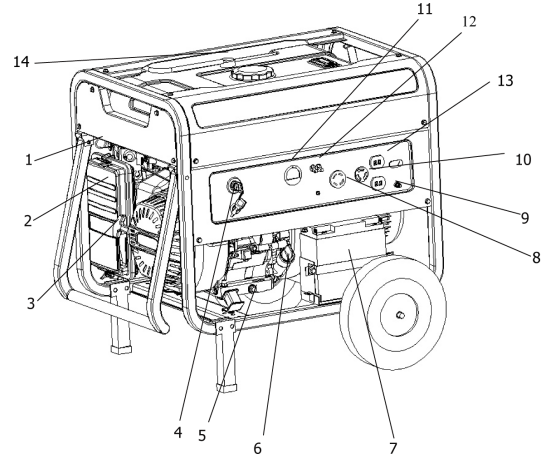
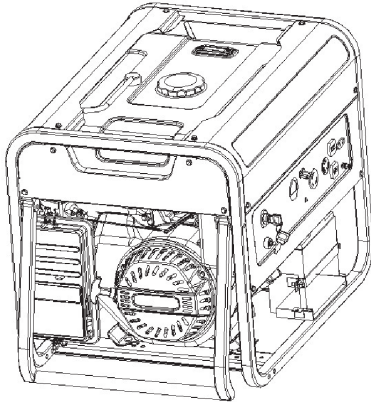

- Refer to Figures to install wheels as shown.
- Slide the axle through the frame brackets.
- Slide on the wheel and flat washer, then assemble flange nuts.
- Refer to Figure to install the bracket as shown.
- Insert an M8 bolt through the bracket. Secure the bolt with an M8 flange nut.
- Insert an M8 bolt through the bracket. Secure the bolt with an M8 flange nut.

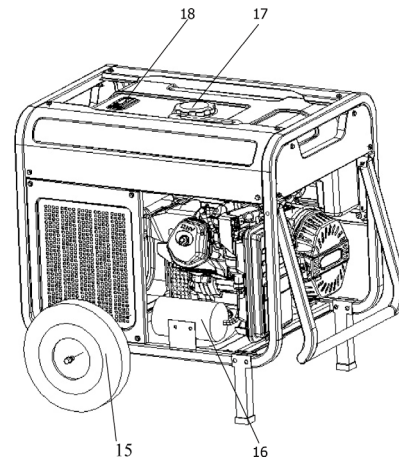

SECTION 3 - FEATURES AND CONTROLS

Read this Operator's Manual and safety rules before operating your generator. Compare the illustrations with your generator to familiarize yourself with the locations of various controls and adjustments. Save this manual for future reference.

1- CHOKE LEVER	10 - 120 VOLT AC, 30 Amp TWIST LOCK RECEPTACLE
2 - AIR CLEANER	11 - VOLTMETER
3 - RECOIL STARTER	12 - AC CIRCUIT BREAKER
4 - ENGINE SWITCH	13 - 120V, 20Amp GFCI DUPLEX RECEPTACLE
5 - OIL DRAIN BOLT	14 - ROLL OVER VALVE
6 - OIL DIPSTICK	15 - WHEEL
7 - BATTERY	16 - CARBON CANISTER
8 - 120/240 VOLT AC, 30 Amp TWIST LOCK RECEPTACLE	17 - FUEL TANK CAP
9 - GROUND TERMINAL	18 - FUEL GAUGE



BN Products-USA™

A DIVISION OF BENNER-NAWMAN, INC.

WWW.BNPRODUCTS.COM

OPERATING INSTRUCTIONS

BNG SERIES GASOLINE GENERATORS

Customer Service: (800) 992-3833

NOTICE - Pictures and drawings used in this manual are for reference only and do not represent any specific model.

SECTION 4 - PREPARATION BEFORE OPERATION

4.1 - ADDING ENGINE OIL

All oil should meet minimum American Petroleum Institute (API) Service Class SJ, SL or better. Use no special additives. Select the oil's Viscosity grade according to the expected operating temperature.

- Above 40°F, use SAE 30
- Below 40°F and down to 10°F, use 10W-30
- Below 1°F, use synthetic 5W-30

NOTICE - Improper treatment of generator could damage it and shorten its life. DO NOT attempt to crank or start the engine before it has been properly serviced with the recommended oil. This could result in an engine failure.

- Place generator on a flat, level surface.
- Clean area around oil fill and remove oil fill cap and dipstick. Wipe dipstick clean.
- Slowly fill engine with oil through the oil fill opening until it reaches the full mark on the dipstick.
- Stop filling occasionally to check oil level. Be careful do not over fill. Do not fill to the top of the tank.
- Install oil fill cap and finger tighten securely.
- Check engine oil level before starting each time thereafter.

4.2 - ADDING FUEL

DANGER - Never fill tank indoors. Never fill fuel tank when engine is running or hot. Turn generator engine OFF and allow engine to cool entirely before filling fuel tank. Avoid spilling gasoline on HOT engine. Keep fuel away from sparks, open flames, pilot lights, heat, and other ignition sources. DO NOT light a cigarette or smoke when filling the fuel tank. Fuel is highly FLAMMABLE and its vapors are EXPLOSIVE.

- Use regular UNLEADED gasoline with the generator engine. Do not use any fuel with more than 10% added ethanol, and never use E85 fuel.
- Do not mix oil with gasoline.

- Install fuel cap and wipe up any spilled gasoline.

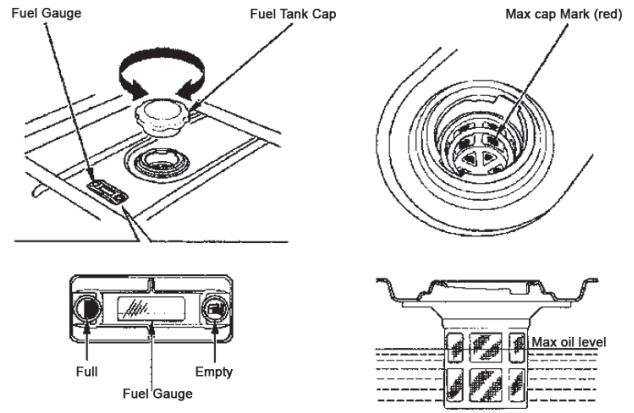

CAUTION - Do not overfill the fuel tank. Allow space for fuel expansion. IF the fuel tank is overfilled, fuel can overflow onto a HOT engine and cause FIRE or EXPLOSION. If fuel spills, wait until it evaporates before starting engine. Check fuel lines, tank, cap and fittings frequently for cracks or leaks. Replace if necessary.

IMPORTANT - It is important to prevent gum deposits from forming in fuel system parts such as the carburetor, fuel hose or tank during storage. Alcohol-blended fuels (called gasohol, ethanol or methanol) can attract moisture, which leads to separation and formation of acids during storage. Acidic gas can damage the fuel system and should be emptied before storage of 30 days or longer. See the "Storage" section. Never use engine or carburetor cleaner products in the fuel tank as permanent damage may occur.





BN Products-USA™

A DIVISION OF BENNER-NAWMAN, INC.

WWW.BNPRODUCTS.COM

OPERATING INSTRUCTIONS

BNG SERIES GASOLINE GENERATORS

Customer Service: (800) 992-3833

4.3 - GROUNDING THE GENERATOR

The national Electrical Code requires that the frame and external electrically conductive part of this generator be properly connected to an approved earth ground.

Local electrical codes may also require proper grounding of the unit. For that purpose, connecting a No. 10 AWG (American Wire Gauge) stranded copper wire to the grounding lug and to an earth-driven copper or brass grounding rod (electrode) provides adequate protection against electrical shock. However, local codes may vary widely. Consult with a local electrician for grounding requirement in the area.

Proper grounding of the generator will help prevent electrical shock in the event of ground fault condition in the generator or in connected electrical devices. Proper grounding also helps dissipate static electricity, which often builds up in ungrounded devices.

IMPORTANT: See page 16 for where to find OSHA information on Ground Fault Circuit Interrupters.

WATTAGE REFERENCE GUIDE

Tool or Appliance	Running* (Rated) Watts	Additional Starting (Surge) Watts
Essentials		
Light Bulb - 75 watt	75	—
Furnace Fan Blower - 1/2 HP	800	2350
Sump Pump - 1/3 HP	800	1300
Refrigerator/ Freezer	700	2200
Water Well Pump - 1/2 HP	1000	2100
Heating/Cooling		
Window AC - 10,000 BTU	1200	3600
Humidifier - 13 Ga	175	—

Central AC - 24,000 BTU	3800	11400
Kitchen		
Microwave Oven - 1000 Watt	1000	—
Coffee Maker	1000	—
Electric Stove - 8" Element	2100	—
Toaster	850	—
Family Room		
DVD/CD Player	100	—
VCR	100	—
Stereo Receiver	450	—
Color Television - 27 in	500	—
Personal Computer w/17 in monitor	800	—
Other		
Security System	500	—
AM/FM Clock Radio	100	—
Garage Door Opener - 1/2 HP	875	2350
Electric Water Heater	4700	11700
Job Site		
Quartz Halogen Work Light	1000	—
Airless Sprayer - 1/3 HP	600	1200
Reciprocating Saw	960	—
Electric Drill - 1/2 HP, 5.4	600	900
Circular Saw - 7-1/4 in	1400	2300
Miter Saw - 10 in	1800	1800
Table Planer - 6 in	1800	1800
Table Saw/Radial Arm Saw	2000	2000
Air Compressor - 1 HP	1600	4500

SECTION 5 — OPERATION



BN Products-USA™

A DIVISION OF BENNER-NAWMAN, INC.

WWW.BNPRODUCTS.COM

OPERATING INSTRUCTIONS

BNG SERIES GASOLINE GENERATORS

Customer Service: (800) 992-3833

5.1 STARTING THE ENGINE

WARNING - Never start or stop engine with electrical devices plugged into the receptacles and devices turned on.

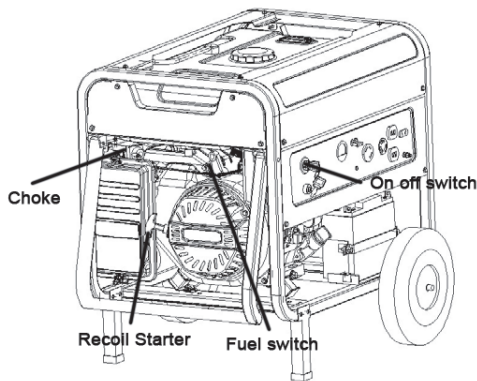

Unplug all electrical loads from the unit's receptacles before starting the engine. Make sure the unit is in a level position.

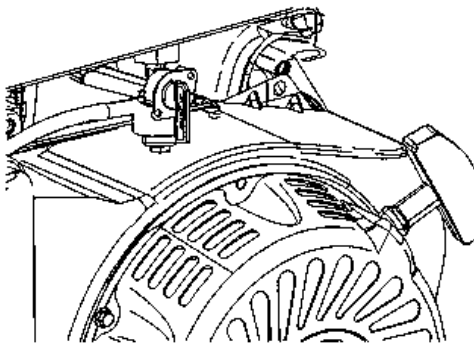

Turn the Fuel Shut-off level Valve to the "On" position. Move engine choke lever to the ON position. For Recoil start, firmly grasp the recoil handle and pull slowly until increased resistance is felt. Pull rapidly up and away.

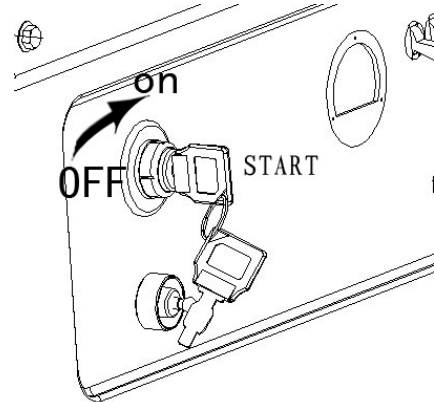

For electric start, turn and hold key in start switch to "start" position until generator starts. To prolong the life of starter components, **DO NOT** hold key in "start" position for more than 15 seconds, and pause for at least 1 minute between starting attempts.

When engine starts, move choke lever to 1/2 - CHOKE position until engine runs smoothly then and fully into ON position. If engine falters, move choke back out to 1/2 - CHOKE position until engine runs smoothly and then fully into ON position.

NOTICE - If battery is discharged, use manual starting instructions.

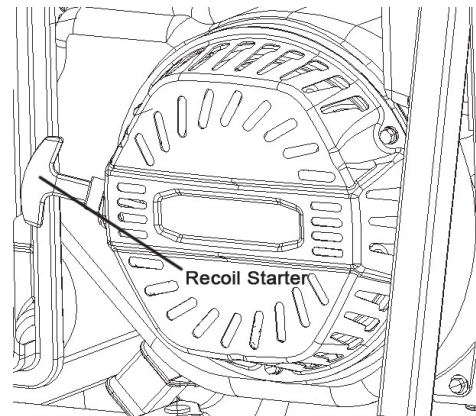

NOTICE - If engine fires, but does not continue to run, move choke lever to the OFF position and repeat starting instructions.



BN Products-USA™

A DIVISION OF BENNER-NAWMAN, INC.

WWW.BNPRODUCTS.COM

OPERATING INSTRUCTIONS

BNG SERIES GASOLINE GENERATORS

Customer Service: (800) 992-3833

WARNING - Starter cord kickback (rapid retraction) will pull hand and arm toward engine faster than you can let go which could cause broken bones, fractures, bruises, or sprains resulting in serious injury.

When starting engine, pull cord slowly until resistance is felt and then pull rapidly to avoid kickback.

Never start or stop engine with electrical devices plugged in and turned on.

NOTICE - If engine starts after 3 pulls but fails to run, or if unit shuts down during operation, make sure unit is on a level surface and check for proper oil level in crankcase. This unit is be equipped with a low oil protection device. Oil must be at proper level for engine to start.

WARNING - Exhaust heat/ gases could ignite combustible, structures or damage fuel tank causing a fire, resulting in death, serious injury and/or property damage. Contact with muffler area could cause burn resulting in serious injury.

DO NOT touch hot muffler and AVOID hot exhaust gases. Allow equipment to cool before touching. Keep at least 5 feet (152 cm) of clearance on all sides of generator including overhead. Contact the original equipment manufacturer, retailer, or dealer to obtain a spark arrester designed for the exhaust system installed on this engine. Replacement parts must be the same and installed in the same position as the original parts.

IMPORTANT - Do not overload the generator. Also, do not overload individual panel receptacles. These outlets are protected against overload with push-to-reset-type circuit breakers. If amperage rating of any circuit breaker is exceeded, that breaker opens and electrical output to that receptacle is lost.

5.2 - CONNECTING ELECTRICAL LOADS

- Let engine stabilize and warm up for a few minutes after starting.
- Plug in and turn on the desired 120 and/or 240 Volt AC, single phase, 60 Hz electrical loads.
- Add up the rated watts (or amps) of all loads to be connected at one time. This total should not be greater than, (a) the rated wattage/amperage capac-

ity of the generator or, (b) circuit breaker rating of the receptacle supplying the power.

NOTICE - DO NOT connect 240 Volt loads to the 120 Volt duplex receptacles.

DO NOT connect 3 phase loads to the generator.

DO NOT connect 50 Hz loads to the generator.

NOTICE - Start generator and let engine stabilize before connecting electrical loads. Connect electrical loads such as tools then turn them ON for operation. Turn electrical loads OFF and disconnect from generator before stopping generator.

NOTICE - Exceeding generators wattage/ amperage capacity could damage generator and/or electrical devices connected to it. DO NOT exceed the generator's wattage/ amperage capacity.

Overloading a generator in excess of its rated wattage capacity can result in damage to the generator and to connected electrical devices. Observe the following to prevent overloading the unit:

Add up the total wattage of all electrical devices to be connected at one time. This total should NOT be greater than the generator's wattage capacity.

The rated wattage of lights can be taken from light bulbs. The rated wattage of tools, appliances and motors can usually be found on a data label or decal affixed to the device.

If the appliance, tool or motor does not give wattage, multiply volts times ampere rating to determine watts (volts × amps = watts).

Some electric motors, such as induction types, require about three times more watts of power for starting than for running. This surge of power lasts only a few seconds when starting such motors. Make sure to allow for high starting wattage when selecting electrical devices to connect to the generator:

Figure the watts needed to start the largest motor. Add to that figure the running watts of all other connected loads.

The wattage reference guide is provided to assist in determining how many items the generator can operate at one



time.

5.3 - STOPPING THE ENGINE

Shut off all loads then unplug the electrical loads from generator panel receptacles. Never start or stop the engine with electrical devices plugged in and turned on. Let engine run at no-load for several minutes to stabilize the internal temperatures of engine and generator. Move ON/OFF switch to OFF position. Close fuel valve. See wattage table on page 16

5.4 - LOW OIL LEVEL SHUTDOWN SYSTEM

The engine is equipped with a low oil level sensor that shuts down the engine automatically when the oil level drops below a specified level. If the engine shuts down by itself and the fuel tank has enough gasoline, check engine oil level.

5.5 - HIGH ALTITUDE

At altitudes over 5,000 feet (1524 meters), a minimum 85 octane / 85 (89 RON) gasoline is acceptable. To remain emissions compliant, high altitude adjustment is required. Operation without this adjustment will cause decreased performance, increased fuel consumption, and increased emissions. See an authorized dealer for high altitude adjustment information. Operation of the engine at altitudes below 2,500 feet (762 meters) with the high altitude kit is not recommended.

SECTION 6 - MAINTENANCE

6.1 - MAINTENANCE SCHEDULE

Follow the calendar intervals. More frequent service is required when operating in adverse conditions noted below.

First 8 Hours
• Change engine oil
Every 8 Hours or Daily
• Clean debris
• Check engine oil level
Every 25 Hours or Every Season
• Clean engine air filter
Every 20 Hours or Every Season
• Change engine oil
Yearly
• Replace engine air filter
• Service fuel valve
• Service spark plug
• Inspect muffler and spark arrester
• Clean cooling system

Note - Change the oil more often when operating under heavy loads or in high temperatures. Clean the air filter more often under dirty or dusty operating conditions

6.2 - GENERAL RECOMMENDATIONS

The warranty of the generator does not cover items that have been subjected to operator abuse or negligence. To receive full value from the warranty, the operator must maintain the generator as instructed in this manual.

Some adjustments will need to be made periodically to properly maintain the generator.

All adjustments in the Maintenance section of this manual should be made at least once each season. Follow the requirements in the "Maintenance Schedule."

NOTE - Once a year replace the spark plug and replace the air filter. A new spark plug and clean air filter assure proper fuel-air mixture and help the engine run better and last longer.

6.2.1 - GENERATOR MAINTENANCE



BN Products-USA™

A DIVISION OF BENNER-NAWMAN, INC.

WWW.BNPRODUCTS.COM

OPERATING INSTRUCTIONS

BNG SERIES GASOLINE GENERATORS

Customer Service: (800) 992-3833

Generator maintenance consists of keeping the unit clean and dry. Operate and store the unit in a clean dry environment where it will not be exposed to excessive dust, dirt, moisture or any corrosive vapors. Cooling air slots in the generator must not become clogged with snow, leaves, or any other foreign material.

Check the cleanliness of the generator frequently and clean when dust, dirt, oil, moisture or other foreign substances are visible on its exterior surface.

CAUTION - Never insert any object or tool through the air cooling slots, even if the engine is not running.

NOTE - DO NOT use a garden hose to clean generator. Water can enter the engine fuel system and cause problem. In addition, if water enters the generator through cooling air slots, some water will be retained in voids and crevices of the rotor and stator winding insulation. Water and dirt buildup on the generator internal windings will eventually decrease the insulation resistance of these windings.

6.2.2 - TO CLEAN THE GENERATOR

- Use a damp cloth to wipe exterior surfaces clean.
- A soft bristle brush may be used to loosen caked-on dirt, oil etc.
- A vacuum cleaner may be used to pick up loose dirt and debris.
- Low pressure air (not to exceed 25 psi) may be used to blow away dirt. Inspect cooling air slots and openings on the generator. These openings must be kept clean and unobstructed.

6.2.3 ENGINE MAINTENANCE

DANGER - When working on the generator, always disconnect spark plug wire from spark plug and keep wire away from spark plug.

6.2.4 CHANGE OIL

Change the oil after the first eight hours of operation, then every 20 hours thereafter. If running this unit under dirty or dusty conditions, or in extremely hot weather, change the oil more often.

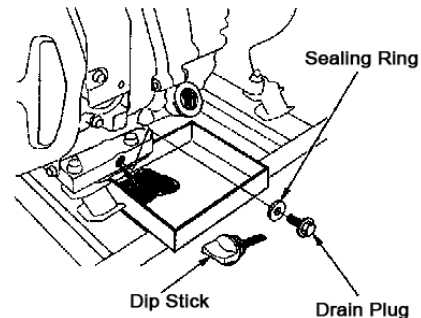

CAUTION Hot oil may cause burns. Allow engine to cool before draining oil. Avoid prolonged or repeated skin exposure with used oil. Thoroughly wash exposed areas with soap.

Use the following instructions to change the oil while the engine is still warm:

- Clean area around oil drain plug.
- Remove oil drain plug from engine and oil fill plug to drain oil completely into a suitable container.
- When oil has completely drained, install oil drain plug and tighten securely.
- Fill engine with recommended oil. (See "ADDING ENGINE OIL" for oil recommendations).
- Wipe up any spilled oil.
- Dispose of used oil at a proper collection center.

6.2.5 REPLACE THE SPARK PLUG

Use spark plug F6RTC. Replace the plug once each year. This will help the engine start easier and run better.

- Stop the engine and pull the spark plug wire off of the spark plug.
- Clean the area around the spark plug and remove it from the cylinder head.
- Set the spark plug's gap to 0.70-0.80 mm (0.028-0.031 in.). Install the correctly gapped spark plug into the cylinder head and torque to 15 ft/lbs.

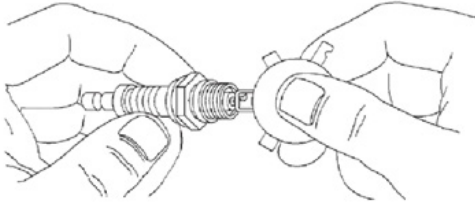

6.2.6 SPARK ARRESTOR

- Shut off generator and allow the engine and muffler to cool down completely before servicing spark arrestor (located on the back of the muffler).
- Remove the clamp and spark arrestor screen.
- Clean the spark arrestor screen with a small wire brush.
- Replace the spark arrestor if it is damaged.
- Installation of the spark arrestor screen is the reverse of the removal.

6.3 SERVICE AIR FILTER

The engine will not run properly and may be damaged if using a dirty air filter. Replace the air filter once a year. Clean or replace more often if operating under dusty conditions.

- Remove air filter cover.
- Wash in soapy water. Squeeze filter dry with clean cloth (DO NOT TWIST).
- Clean air filter cover before re-installing it.

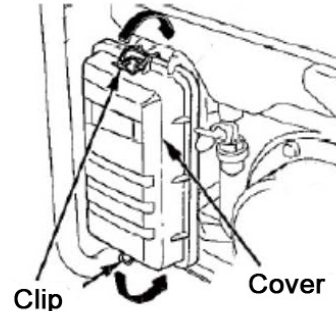

6.4 - VALVE CLEARANCE

After the first 50 hours of operation, check the valve clearance in the engine and adjust if necessary.

Important: If you are not comfortable with this procedure or the proper tools are not available, please take the generator to the nearest service center to have the valve clearance adjusted. This is a very important step to ensure longest life for the engine.

6.5 - GENERAL

The generator should be started at least once every seven days and be allowed to run at least 30 minutes. If this cannot be done and the unit must be stored for more than 30 days, use the following information as a guide to prepare it for storage.

DANGER - NEVER store engine with fuel in tank indoors or in enclosed, poorly ventilated areas where fumes may reach an open flame, spark or pilot light as on a furnace, water heater, clothes dryer or other gas appliance.

CAUTION - Avoid spray from spark plug holes when cranking engine.



BN Products-USA™

A DIVISION OF BENNER-NAWMAN, INC.

WWW.BNPRODUCTS.COM

OPERATING INSTRUCTIONS

BNG SERIES GASOLINE GENERATORS

Customer Service: (800) 992-3833

DANGER - Drain fuel into approved container outdoors, away from open flame. Be sure engine is cool. Do not smoke.

DANGER - NEVER cover the generator while engine and exhaust area are warm.

SECTION 7 - STORAGE

It is important to prevent gum deposits from forming in essential fuel system parts such as the carburetor, fuel hose or tank during storage. Also, experience indicates that alcohol-blended fuels (called gasohol, ethanol or methanol) can attract moisture, which leads to separation and formation of acids during storage. Acidic gas can damage the fuel system of an engine while in storage. To avoid engine problems, the fuel system should be emptied before storage of 30 days or longer, as follows:

Remove all gasoline from the fuel tank.

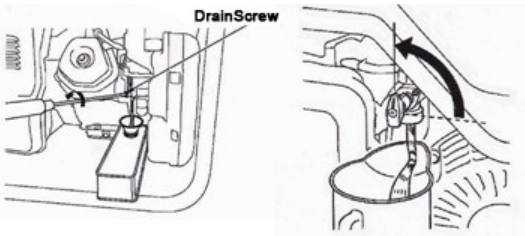

- Start and run engine until engine stops from lack of fuel.
- While engine is still warm, drain oil from crankcase. Refill with recommended grade.
- Remove spark plugs and pour about 1/2 ounce (15 ml) of engine oil in the cylinders. Cover spark plug hole with rag. Pull the recoil starter a couple times to lubricate the piston rings and cylinder bore.

Install and tighten spark plugs. Do not connect spark plug wires.

- Clean the generator outer surfaces. Check that cooling air slots and openings on generator are open and unobstructed.
- Store the unit in clean, dry place.
- Do not store gasoline from one season to another.
- Replace the gasoline can if it has started to rust. Rust and/or dirt in the gasoline will cause problems with the carburetor and fuel system.

- If possible, store the unit indoors and cover it to give protection from dust and dirt. **BE SURE TO EMPTY THE FUEL TANK.**

If it is not practical to empty the fuel tank and the unit is to be stored for some time, use a commercially available fuel stabilizer added to the gasoline to increase the life of the gasoline.

- Cover the unit with a suitable protective cover that does not retain moisture.

SECTION 8 - WARRANTY

We welcome warranty repair and apologize to you for being inconvenienced. Any Authorized Service Dealer may perform warranty repairs. Consumer sales are warranted for one (1) year. Most warranty repairs are handled routinely, but sometimes requests for warranty service may not be appropriate. For example, warranty service would not apply if equipment damage occurred because of misuse, lack of routine maintenance, shipping, handling, warehousing or improper installation. Similarly, the warranty is void if the manufacturing date or the serial number on the portable generator has been removed or the equipment has been altered or modified. During the





BN Products-USA™

A DIVISION OF BENNER-NAWMAN, INC.

WWW.BNPRODUCTS.COM

OPERATING INSTRUCTIONS

BNG SERIES GASOLINE GENERATORS

Customer Service: (800) 992-3833

warranty period, the Authorized Service Dealer, at its option, will repair or replace any part that, upon examination, is found to be defective under normal use and service. This warranty will not cover the following repairs and equipment:

- **REGULAR WEAR:** Outdoor Power Equipment, as with all mechanical devices, need periodic part(s) service and replacement to perform as designed. This warranty will not cover repair when normal use has exhausted the lifetime of a part(s) or engine.
- **INSTALLATION AND MAINTENANCE:** This warranty does not cover the generator or parts when they have been subjected to improper or unauthorized use, assembly, altered, modified, or damage due to misuse, negligence, accident, overloading, over-speeding, improper maintenance, repair or storage so as, in our judgment, to adversely affect its performance and reliability. This warranty also does not cover regular maintenance and parts such as air filters, adjustments, fuel system cleaning and obstruction (due to chemical, dirt, carbon, lime, and so forth).
- **OTHER EXCLUSIONS:** This warranty excludes wearing parts such as o-rings, filters, etc., or malfunctions resulting from accidents, abuse, modifications, alterations, or improper servicing or freezing or chemical deterioration; Damaged related to rodent and/or insect infestation.

Accessory parts such as starting batteries, generator adapter cord sets and storage covers are excluded from the product warranty. This warranty excludes used, reconditioned, and demonstration equipment, equipment used for prime power in place of utility power, equipment used in life support applications, and failures due to acts of God and other force majeure events beyond the manufacturers control, such as collision, theft, vandalism, riot or wars, nuclear holocaust, fire, freezing, lightning, earthquake, windstorm, hail, volcanic eruption, water or flood, tornado or hurricane.

SECTION 9 - TROUBLESHOOTING

Problem	Cause	Correction
Engine is running but no AC output is available	1. One of the circuit breakers is off. 2. Fault in generator. 3. Poor connection or defective cord set. 4. Connected device is bad.	1. Turn circuit breaker to ON. 2. Contact Authorized Service facility. 3. Check and repair. 4. Connect another device that is in good condition.
Engine runs good but bogs down when loads are connected.	1. Short circuit in a connected load. 2. Engine speed is too slow. 3. Generator is overloaded. 4. Shorted generator circuit. 5. Clogged or dirty fuel filter.	1. Disconnect shorted electrical load. 2. Contact Authorized Service facility. 3. See Don't Overload Generator. 4. Contact Authorized Service facility. 5. Clean or replace fuel filter.



BN Products-USA™

A DIVISION OF BENNER-NAWMAN, INC.

WWW.BNPRODUCTS.COM

OPERATING INSTRUCTIONS

BNG SERIES GASOLINE GENERATORS

Customer Service: (800) 992-3833

Model	BNG3000	BNG5000	BNG6500	BNG7500	BNG7500-D4	BNG9000
Max Starting Wattage	3,300W	5,500W	7,150W	8,000W	8,000W	9,900W
Rated Wattage / Running Wattage	3,000W	5,000W	6,500W	7,500W	7,500W	9,000W
Voltage	120V	120V/240V	120V/240V	120V/240V	120V/240V	120V/240V
Circuit Breaker	25 A Single Pole Breaker	20.8A Double Pole Breaker	27A Double Pole Breaker	31A Double Pole Breaker	31A Double Pole Breaker	39.5A Double Pole Breaker
Outlets						
NEMA 5-20 GFCI (20 amp max)	(1)	(1)	(1)	(1)	(2) (31A Max together)	(2) (39.5A Max together)
NEMA L5-30 20V 3 Prong (30 amp max)	(1) (25A Max)	(1) (20.8A Max)	(1) (27A Max)	(1) (30A)		
NEMA L14-30 120V/240V 4 Prong (30 amp max)		(1) (20.8A Max)	(1) (27A Max)	(1) (31.25A Max)	(1) (31A Max)	
NEMA 14-50R 125V/250V (50 amp max)						(1) (39.5A Max together)
DC 12V, 8.3A	(1)	(1)	(1)	(1)	(1)	(1)

ADDITIONAL SAFETY INFORMATION

California Prop 65 Information

Generators:

WARNING: This product can expose you to chemicals including soots, tars, and mineral oils, which are known to the State of California to cause cancer, and carbon monoxide, which is known to the State of California to cause birth defects or other reproductive harm.

For more information go to www.P65Warnings.ca.gov or scan QR Code



Cal. Prop 65 Information

OSHA GFCI Safety Information

This Generator is equipped with a GFCI (Ground Fault Circuit interrupter) that will work better with the generator grounded. The GFCI is there to protect the user of this unit.

https://www.osha.gov/SLTC/etools/construction/electrical_incidents/gfci.html
or scan QR Code



OSHA GFCI Information