



BN Products-USA™

THE MOST TRUSTED NAME IN REBAR TOOLS

DC-16W

ELECTRIC-HYDRAULIC REBAR CUTTER

#5 REBAR (5/8" - 16MM GRADE 60)

SUMMARY

This portable rebar cutting tool provides safe and efficient rebar cuts for daily or heavy use.

Unlike saws with abrasive blades or cutting torches - the DC-16W eliminates sparks, open flames, or trailing hoses - among other safety hazards. A safety relief valve for retracting the hydraulic piston and a cutting guard are among standard features of the DC-16W!

PORTABILITY

At less than 18 lbs - the power you need, where you need it - and useful for shearing rebar on the job site, or in a shop

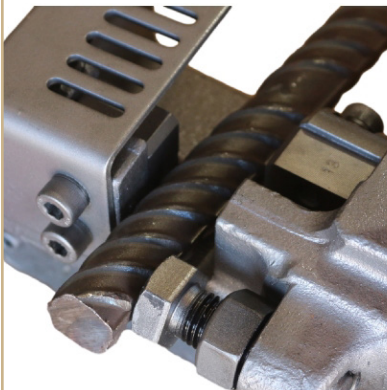

SECURE ADJUSTMENT FOR
FOR ROD DIAMETERS UP
TO 16MM



REMOVABLE HANDLE
• ERGONOMIC
• LIGHTWEIGHT

STANDARD FEATURES

- Safe and clean Rebar cuts up to #5 (5/8" - 16mm)
- 115V A/C - 10A power required; 8' cord length
- Built for heavy, daily use
- Shears Grade 60 rebar in as little as 2.5 seconds
 - 15 tons of cutting pressure
 - Long-lasting cutting blocks
- 18.1" L x 5.9" W x 4.5" H (460mm x 150mm x 115mm)
- 17.6 lbs (8 kg)
- Hydraulic Oil, Tools, Carrying Case



Quality Since 1925

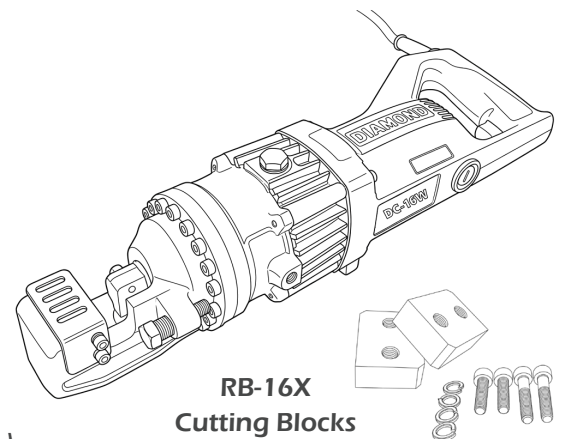

RB-16X
Cutting Blocks

YouTube

PREVIEW:

