



# BN Products-USA™

THE MOST TRUSTED NAME IN REBAR TOOLS

## DC-20WH

### ELECTRIC-HYDRAULIC REBAR CUTTER

**#6 REBAR** (3/4" - 20MM GRADE 60)

#### SUMMARY

This portable rebar cutting tool provides safe and efficient rebar shearing for Grade 60 rebar up to #6 (3/4" - 20mm). The DC-20WH is the top-selling standard and the original hydraulic cutter introduced in North America for clean rebar cutting!

Unlike saws with abrasive blades or cutting torches - the DC-20WH eliminates sparks and open flames - among other safety hazards. A safety relief valve for retracting the hydraulic piston and a cutting guard are among standard features of the DC-20WH.

#### PORTABILITY

At just 25.4 lbs - the power you need, where you need it - and useful for shearing rebar on the job site, or in a shop!



**DIAMOND**

**DC-20WH**



**SECURE ADJUSTMENT FOR  
FOR ROD DIAMETERS UP  
TO 20MM**



**HEAVY-DUTY & PORTABLE**

- ERGONOMIC
- LIGHTWEIGHT

#### STANDARD FEATURES

- Safe and clean Rebar cuts up to #6 (3/4" - 20mm)
- 115V A/C - 10A power required; 8' cord length
- Built for daily contractor use
- Shears Grade 60 rebar in as little as 3 seconds
  - 15 tons of cutting pressure
  - Long-lasting cutting blocks
- 16" L x 4.3" W x 8.2" H (410mm x 110mm x 210mm)
- 25.4 lbs (11.5 kg)
- Hydraulic Oil, Tools, Carrying Case



*Quality Since 1925*

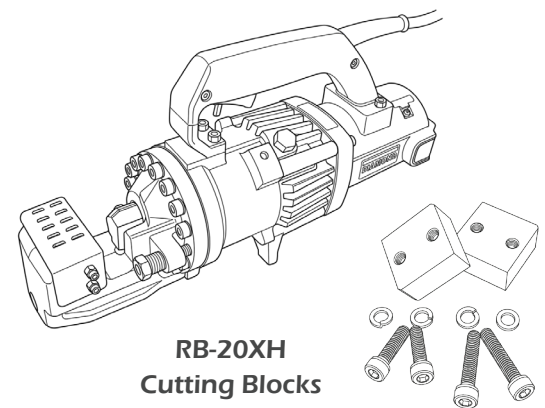

**RB-20XH  
Cutting Blocks**

 YouTube

PREVIEW:

