



# BN Products-USA™

THE MOST TRUSTED NAME IN REBAR TOOLS

## DC-25X

### ELECTRIC-HYDRAULIC REBAR CUTTER

#8 REBAR (1" - 25MM GRADE 60)

#### SUMMARY

This portable rebar cutting tool provides safe and efficient rebar cuts for heavy-duty contractor use. Slightly larger than the popular DC-20WH, the DC-25X effortlessly shears #8 - 1" (25mm) Grade 60 bar where larger diameters are used or required.

Unlike saws with abrasive blades or cutting torches - the DC-25X eliminates sparks and open flames - among other safety hazards. A safety relief valve for retracting the hydraulic piston and a cutting guard are among standard features of the DC-25X Cutter.

#### PORTABILITY

At just under 50 lbs - the DC-25X has all the power you need in a heavy-duty shear, and is easy to move... to just where you need it!



DC-25X



SECURE ADJUSTMENT FOR  
FOR ROD DIAMETERS UP  
TO 1" (25MM)

- Ideal for Job Site or Small Fabrication Shop
- No Heat, Sparks, or Flame

#### STANDARD FEATURES

- Safe and clean Rebar cuts up to #8 (1" - 25 mm)
- 115V A/C - 12A power required; 8' cord length
- Built for medium-duty use
- Shears Grade 60 rebar in as little as 5 seconds
  - 30 tons of cutting pressure
  - Long-lasting cutting blocks
- 20" L x 9.8" W x 5.9" H (515mm x 250mm x 150mm)
- 49.6 lbs (22.5 kg)
- Hydraulic Oil, Tools, Carrying Case

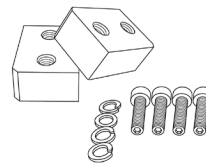

RB-25X  
Cutting Blocks

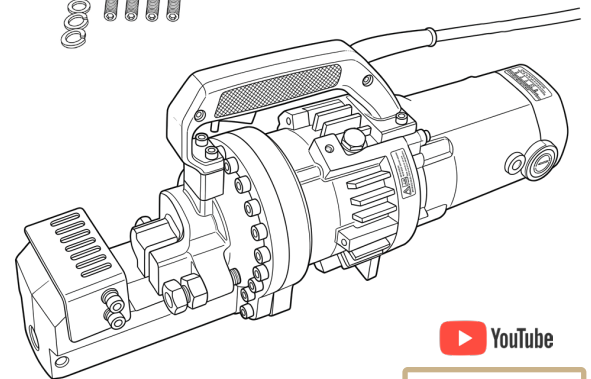

YouTube

PREVIEW:



Quality Since 1925