



BN Products-USA™

THE MOST TRUSTED NAME IN REBAR TOOLS

DCC-2036BHL

CORDLESS HYDRAULIC REBAR CUTTER

#6 REBAR (3/4" - 20 MM GRADE 60)

SUMMARY

This portable rebar cutting tool provides safe and efficient rebar shearing for Grade 60 rebar up to #6 (3/4" - 20 mm). The DCC-2036BHL is the 36V cordless version of our popular #6 hydraulic rebar cutting tools.

This cutter is a self-contained electric-over-hydraulic unit designed for cold-cutting, meaning that it produces no sparks or heat during operation. A safety relief valve for retracting the hydraulic piston and a cutting guard are among standard features of the hydraulic cutters from BN Products-USA™.

PORTABILITY

At under 21 lbs - the power you need, where you need it - and useful for shearing rebar on the job site, or in a shop!



DIAMOND

DCC-2036BHL

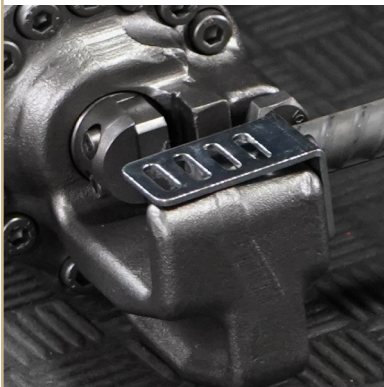

SECURE ADJUSTMENT FOR FOR ROD DIAMETERS UP TO 20 MM



POWERFUL & PORTABLE CORDLESS & ERGONOMIC

STANDARD FEATURES

- Safe and clean Rebar cuts up to #6 (3/4" - 20 mm)
- TWO 36V Multi-Volt Batteries & Rapid Charger
- Shears Grade 60 rebar in as little as 4-6 seconds
 - 15 tons of cutting pressure
 - Long-lasting cutting blocks
- 15.25" L x 4.1" W x 10.7" H (387 mm x 103 mm x 274 mm)
- 20.5 lbs (9.3 kg)
- Hydraulic Oil, Tools, Carrying Case

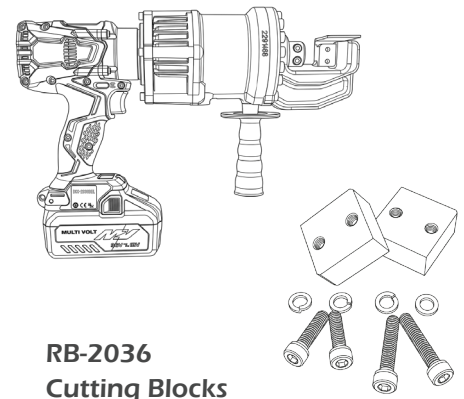

RB-2036 Cutting Blocks

YouTube

PREVIEW:



Quality Since 1925