



THE MOST TRUSTED NAME IN REBAR TOOLS

Quality Since 1925

**BN Products-USA™**

A DIVISION OF BENNER-NAWMAN, INC.

**DC-32WH2**

**ELECTRIC-HYDRAULIC  
REBAR CUTTER**

**#10 REBAR (1-1/4" / 32 mm GRADE 60)**

**SUMMARY**

This heavy-duty rebar cutting tool provides safe and efficient rebar cuts for daily contractor use. Larger than the popular DC-20WH and DC-25X cutters, the DC-32WH2 effortlessly shears #10, 1-1/4" (32 mm) Grade 60 bar where larger diameters are used or required.

Unlike saws with abrasive blades or cutting torches - the DC-32WH2 eliminates sparks and pen flames - among other safety hazards. A safety relief valve for retracting the hydraulic piston and a cutting guard are among standard features of the DC-32WH2 Cutter.

**PORTABILITY**

The DC-32WH2 packs 45 tons of cutting pressure into a 80-lb. package, making it portable to almost any job site, where you need the power of a heavy-duty shear!



**DIAMOND**

**DC-32WH2**

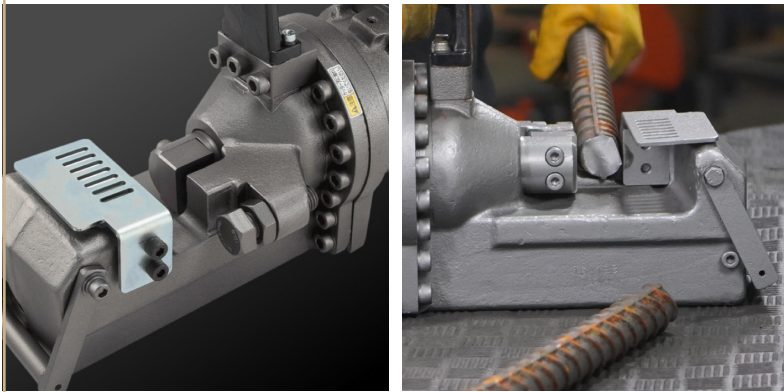

**SECURE ADJUSTMENT FOR  
FOR ROD DIAMETERS UP  
TO 1-1/4" (32 mm)**

- Ideal for Job Site or Small Fabrication Shop
- No Heat, Sparks, or Flame

**STANDARD FEATURES**

- Safe and clean Rebar cuts up to #10 (1-1/4" - 32 mm)
- 115V A/C - 18A power required; 8' cord length
- Built for heavy-duty use and larger rebar diameters
- Shears Grade 60 rebar in as little as 7 seconds
  - 45 tons of cutting pressure
  - Long-lasting cutting blocks
- 23.1" L x 7.1" W x 10.6" H (590 mm x 180 mm x 270 mm)
- 80.5 lbs (36.5 kg)
- Hydraulic Oil, Tool Kit, Wood Storage Case

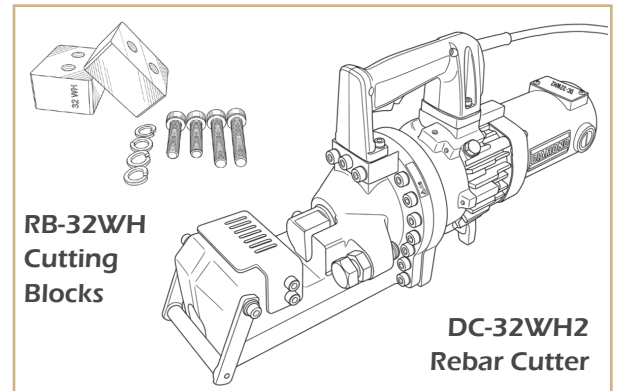

**RB-32WH  
Cutting  
Blocks**

**DC-32WH2  
Rebar Cutter**



PREVIEW:

